

# RISING TIDE TOWERS II

## RISING TIDE TOWERS II

5 MILK STREET  
SUITE 110  
PORTLAND, ME 04101

**POWNA, VT  
SITE #: RTT2-01**

**SITE NAME: POWNAL, VT**  
**SITE NO.: RTT2-01**  
**LATITUDE: 42°45'26.15" N**  
**LONGITUDE: 73°15'31.79" W**

CONSTRUCTION DRAWINGS

C	04/23/25	FOR COMMENT
B	01/08/25	FOR COMMENT
A	11/14/24	FOR COMMENT



Dewberry Engineers Inc.  
99 SUMMER STREET  
SUITE 700  
BOSTON, MA 02110  
PHONE: 617.695.3400  
FAX: 617.695.3310



VICINITY MAP

SITE ADDRESS:  
127 CROW HILL ROAD  
POWNA, VT 05261

APPLICANT:  
RISING TIDE TOWERS 2, LLC  
5 MILK STREET, SUITE 110  
PORTLAND, ME 04101

PROPERTY OWNER:  
BRUCE & JULIE MACDONALD  
719 NW HILL ROAD  
POWNA, VT 05261

ELECTRICAL COMPANY:  
GREEN MOUNTAIN POWER  
1-888-835-4672

TELEPHONE COMPANY:  
FIRSTLIGHT FIBER  
1-833-484-0404

PROJECT SUMMARY

TOWER & FOUNDATION DESIGN:  
COMPLETED BY: SABRE INDUSTRIES  
DATED: T.B.D.

TOPOGRAPHIC SURVEY & EXISTING CONDITIONS PLAN MACDONALD PROPERTY:  
COMPLETED BY: COLONIAL SURVEY CO, INC.  
DATED: 10/24/2024

REFERENCE DOCUMENTS

SHEET NUMBER	SHEET TITLE
T-1	TITLE SHEET
G-1	GENERAL NOTES
Z-1	ABUTTERS PLAN
C-1	PROPOSED SITE & GRADING PLAN
C-2	ACCESS ROAD PROFILE
C-3	PROPOSED COMPOUND PLAN
C-4A	PROPOSED NORTH ELEVATION
C-4B	PROPOSED EAST ELEVATION
C-5	CONSTRUCTION DETAILS-I
C-6	CONSTRUCTION DETAILS-II
C-7	CONSTRUCTION DETAILS-III
E-1	ELECTRICAL & TELCO RISER DIAGRAM
E-2	SCHEMATIC GROUNDING PLAN
E-3	GROUNDING DETAILS

SHEET INDEX

THIS DOCUMENT WAS DEVELOPED TO REFLECT A SPECIFIC SITE AND ITS SITE CONDITIONS AND IS NOT TO BE USED FOR ANOTHER SITE OR WHEN OTHER CONDITIONS PERTAIN. REUSE OF THIS DOCUMENT IS AT THE SOLE RISK OF THE USER.

CONTRACTOR SHALL VERIFY ALL PLANS AND EXISTING DIMENSIONS AND CONDITIONS ON THE JOB SITE AND SHALL IMMEDIATELY NOTIFY THE PROJECT MANAGER IN WRITING OF ANY DISCREPANCIES BEFORE PROCEEDING WITH THE WORK OR BE RESPONSIBLE FOR SAME.

A.D.A. COMPLIANCE:  
FACILITY IS UNMANNED AND NOT FOR HUMAN HABITATION.

GENERAL DISCLAIMERS

DRAWN BY: GMT

REVIEWED BY: DAS

CHECKED BY: BBR

PROJECT NUMBER: 50170469

JOB NUMBER: 50184159

SITE ADDRESS

127 CROW HILL ROAD  
POWNA, VT 05261

SHEET TITLE

TITLE SHEET

SHEET NUMBER

T-1

## GENERAL CONSTRUCTION NOTES:

- ALL WORK SHALL CONFORM TO ALL CURRENT APPLICABLE FEDERAL, STATE, AND LOCAL CODES, INCLUDING ANSI/EIA/TIA-222, AND COMPLY WITH RISING TIDE TOWERS SPECIFICATIONS.
- CONTRACTOR SHALL CONTACT DIG SAFE (1 888 DIG SAFE 888-344-7233) FOR IDENTIFICATION OF UNDERGROUND UTILITIES PRIOR TO START OF CONSTRUCTION.
- CONTRACTOR IS RESPONSIBLE FOR COORDINATING ALL REQUIRED INSPECTIONS.
- ALL DIMENSIONS TO, OF, AND ON EXISTING BUILDINGS, DRAINAGE STRUCTURES, AND SITE IMPROVEMENTS SHALL BE VERIFIED IN FIELD BY CONTRACTOR WITH ALL DISCREPANCIES REPORTED TO THE ENGINEER.
- DO NOT CHANGE SIZE OR SPACING OF STRUCTURAL ELEMENTS.
- DETAILS SHOWN ARE TYPICAL; SIMILAR DETAILS APPLY TO SIMILAR CONDITIONS UNLESS OTHERWISE NOTED.
- THESE DRAWINGS DO NOT INCLUDE NECESSARY COMPONENTS FOR CONSTRUCTION SAFETY WHICH IS THE SOLE RESPONSIBILITY OF THE CONTRACTOR.
- CONTRACTOR SHALL BRACE STRUCTURES UNTIL ALL STRUCTURAL ELEMENTS NEEDED FOR STABILITY ARE INSTALLED. THESE ELEMENTS ARE AS FOLLOWS: LATERAL BRACING, ANCHOR BOLTS, ETC.
- CONTRACTOR SHALL DETERMINE EXACT LOCATION OF EXISTING UTILITIES, GROUNDS DRAINS, DRAIN PIPES, VENTS, ETC. BEFORE COMMENCING WORK.
- INCORRECTLY FABRICATED, DAMAGED, OR OTHERWISE MISFITTING OR NONCONFORMING MATERIALS OR CONDITIONS SHALL BE REPORTED TO THE OWNER PRIOR TO REMEDIAL OR CORRECTIVE ACTION. ANY SUCH REMEDIAL ACTION SHALL REQUIRE WRITTEN APPROVAL BY THE OWNER'S REPRESENTATIVE PRIOR TO PROCEEDING.
- EACH CONTRACTOR SHALL COOPERATE WITH THE OWNER'S REPRESENTATIVE, AND COORDINATE HIS WORK WITH THE WORK OF OTHERS.
- CONTRACTOR SHALL REPAIR ANY DAMAGE CAUSED BY CONSTRUCTION OF THIS PROJECT TO MATCH EXISTING PRE-CONSTRUCTION CONDITIONS TO THE SATISFACTION OF THE RISING TIDE TOWERS CONSTRUCTION MANAGER.
- ALL CABLE/CONDUIT ENTRY/EXIT PORTS SHALL BE WEATHERPROOFED DURING INSTALLATION USING A SILICONE SEALANT.
- WHERE EXISTING CONDITIONS DO NOT MATCH THOSE SHOWN IN THIS PLAN SET, CONTRACTOR WILL NOTIFY ENGINEER, RISING TIDE TOWERS PROJECT CONSTRUCTION MANAGER, AND LANDLORD IMMEDIATELY.
- CONTRACTOR SHALL ENSURE ALL SUBCONTRACTORS ARE PROVIDED WITH A CURRENT SET OF DRAWINGS AND SPECIFICATIONS FOR THIS PROJECT.
- CONTRACTOR SHALL REMOVE ALL RUBBISH AND DEBRIS FROM THE SITE AT THE END OF EACH DAY.
- CONTRACTOR SHALL COORDINATE WORK SCHEDULE WITH LANDLORD AND TAKE PRECAUTIONS TO MINIMIZE IMPACT AND DISRUPTION OF OTHER OCCUPANTS OF THE FACILITY.
- CONTRACTOR SHALL FURNISH RISING TIDE TOWERS II WITH THREE AS-BUILT SETS OF DRAWINGS UPON COMPLETION OF WORK.
- ANTENNAS AND CABLES ARE TYPICALLY PROVIDED BY RISING TIDE TOWERS II. PRIOR TO SUBMISSION OF BID, CONTRACTOR SHALL COORDINATE WITH RISING TIDE TOWERS II PROJECT MANAGER TO DETERMINE WHAT, IF ANY, ITEMS WILL BE PROVIDED BY RISING TIDE TOWERS II. ALL ITEMS NOT PROVIDED BY RISING TIDE TOWERS II SHALL BE PROVIDED AND INSTALLED BY THE CONTRACTOR. CONTRACTOR WILL INSTALL ALL ITEMS PROVIDED BY RISING TIDE TOWERS II.
- PRIOR TO SUBMISSION OF BID, CONTRACTOR WILL COORDINATE WITH RISING TIDE TOWERS PROJECT MANAGER TO DETERMINE IF ANY PERMITS WILL BE OBTAINED BY RISING TIDE TOWERS. ALL REQUIRED PERMITS NOT OBTAINED BY RISING TIDE TOWERS MUST BE OBTAINED, AND PAID FOR, BY THE CONTRACTOR.
- CONTRACTOR SHALL START UP HVAC UNITS AND SYNCHRONIZE THE THERMOSTATS.
- CONTRACTOR SHALL INSTALL ALL SITE SIGNAGE IN ACCORDANCE WITH RISING TIDE TOWERS SPECIFICATIONS AND REQUIREMENTS.
- CONTRACTOR SHALL SUBMIT ALL SHOP DRAWINGS TO ENGINEER FOR REVIEW AND APPROVAL PRIOR TO FABRICATION.
- UNLESS OTHERWISE NOTED RISING TIDE TOWERS II SHALL PROVIDE ALL REQUIRED RF MATERIAL FOR CONTRACTOR TO INSTALL, INCLUDING ANTENNAS, TMA'S, BIAS-T'S, COMBINERS, PDU, DC BLOCKS, SURGE ARRESTORS, GPS ANTENNA, GPS SURGE ARRESTOR, COAXIAL CABLE.
- PRIOR TO SUBMISSION OF BID, CONTRACTOR SHALL VERIFY ALL EQUIPMENT TO BE PROVIDED BY RISING TIDE TOWERS FOR INSTALLATION BY CONTRACTOR.
- ALL EQUIPMENT SHALL BE INSTALLED ACCORDING TO MANUFACTURER'S SPECIFICATIONS AND LOCATED ACCORDING TO RISING TIDE TOWERS SPECIFICATIONS, AND AS SHOWN IN THESE PLANS.
- SEAL PENETRATIONS THROUGH FIRE RATED AREAS WITH UL LISTED D FIRE CODE APPROVED MATERIALS.
- REPAIR ANY DAMAGE DURING CONSTRUCTION TO MATCH EXISTING PRE-CONSTRUCTION CONDITIONS TO THE SATISFACTION OF THE CONSTRUCTION MANAGER.
- THE CONTRACTOR SHALL SUPERVISE AND DIRECT THE PROJECT DESCRIBED HEREIN. THE CONTRACTOR SHALL BE SOLELY RESPONSIBLE FOR ALL THE CONSTRUCTION MEANS, METHODS, TECHNIQUES, SEQUENCES AND PROCEDURES AND FOR COORDINATING ALL PORTIONS OF THE WORK UNDER THE CONTRACT.
- CONTRACTOR SHALL NOTIFY DEWBERRY A MINIMUM OF 48 HOURS IN ADVANCE OF POURING CONCRETE OR BACKFILLING ANY UNDERGROUND UTILITIES, FOUNDATIONS OR SEALING ANY WALL, FLOOR OR ROOF PENETRATIONS FOR ENGINEERING REVIEW AND APPROVAL.
- CONTRACTOR SHALL BE RESPONSIBLE FOR SITE SAFETY INCLUDING COMPLIANCE WITH ALL APPLICABLE OSHA STANDARDS AND RECOMMENDATIONS AND SHALL PROVIDE ALL NECESSARY SAFETY DEVICES INCLUDING PPE AND PPM AND CONSTRUCTION DEVICES SUCH AS WELDING AND FIRE PREVENTION, TEMPORARY SHORING, SCAFFOLDING, TRENCH BOXES/SLOPING, BARRIERS, ETC.

## CONCRETE AND REINFORCING STEEL NOTES:

- DESIGN AND CONSTRUCTION OF ALL CONCRETE ELEMENTS SHALL CONFORM TO THE LATEST EDITIONS OF ALL APPLICABLE CODES INCLUDING: ACI 301 "SPECIFICATIONS FOR STRUCTURAL CONCRETE FOR BUILDINGS", AND ACI 318 "BUILDING CODE REQUIREMENTS FOR REINFORCED CONCRETE".
- MIX DESIGN SHALL BE APPROVED BY OWNER'S REPRESENTATIVE AND SUBMITTED TO ENGINEER PRIOR TO PLACING CONCRETE.
- CONCRETE SHALL BE NORMAL WEIGHT, 6 % AIR ENTRAINED (+/- 1.5%) WITH A MAXIMUM 4" SLUMP AND HAVE A MINIMUM 28-DAY COMPRESSIVE STRENGTH OF 4000 PSI UNLESS OTHERWISE NOTED.
- THE FOLLOWING MATERIALS SHALL BE USED:
 

PORTLAND CEMENT:	ASTM C-150, TYPE 1 OR 2
REINFORCEMENT:	ASTM A-185, PLAIN STEEL WELDED WIRE FABRIC
REINFORCEMENT BARS:	ASTM A615, GRADE 60, DEFORMED
NORMAL WEIGHT AGGREGATE:	ASTM C-33
WATER:	DRINKABLE
ADMIXTURES:	NON-CHLORIDE CONTAINING
- MINIMUM CONCRETE COVER FOR REINFORCING STEEL SHALL BE AS FOLLOWS, UNLESS OTHERWISE NOTED:
 

A. CONCRETE CAST AGAINST EARTH: 3"

B. ALL OTHER CONCRETE: 2"
- A 3/4" CHAMFER SHALL BE PROVIDED AT ALL EXPOSED EDGES OF CONCRETE IN ACCORDANCE WITH ACI 301 SECTION 4.2.4, UNLESS NOTED OTHERWISE.
- INSTALLATION OF CONCRETE EXPANSION/WEDGE ANCHOR SHALL BE PER MANUFACTURER'S WRITTEN RECOMMENDED PROCEDURE. THE ANCHOR BOLT, DOWEL, OR ROD SHALL CONFORM TO MANUFACTURER'S RECOMMENDATION FOR EMBEDMENT DEPTH OR AS SHOWN ON THE DRAWINGS. NO REBAR SHALL BE CUT WITHOUT PRIOR ENGINEERING APPROVAL WHEN DRILLING HOLES IN CONCRETE.
- ADMIXTURES SHALL CONFORM TO THE APPROPRIATE ASTM STANDARD AS REFERENCED IN ACI 301.
- DO NOT WELD OR TACK WELD REINFORCING STEEL.
- ALL DOWELS, ANCHOR BOLTS, EMBEDDED STEEL, ELECTRICAL CONDUITS, PIPE SLEEVES, GROUNDS AND ALL OTHER EMBEDDED ITEMS AND FORMED DETAILS SHALL BE IN PLACE BEFORE START OF CONCRETE PLACEMENT.
- REINFORCEMENT SHALL BE COLD BENT WHENEVER BENDING IS REQUIRED.
- DO NOT PLACE CONCRETE IN WATER, ICE, OR ON FROZEN GROUND.
- DO NOT ALLOW REINFORCEMENT, CONCRETE OR SUBBASE TO FREEZE DURING CONCRETE CURING AND SETTING PERIOD, OR FOR A MINIMUM OF 3 DAYS AFTER PLACEMENT.
- FOR COLD-WEATHER AND HOT-WEATHER CONCRETE PLACEMENT, CONFORM TO APPLICABLE ACI CODES AND RECOMMENDATIONS. IN EITHER CASE, MATERIALS CONTAINING CHLORIDE, CALCIUM, SALTS, ETC. SHALL NOT BE USED. PROTECT FRESH CONCRETE FROM WEATHER FOR 7 DAYS, MINIMUM.
- CONCRETE SHALL BE RUBBED TO A ROUGH GROUT FINISH. PADS SHALL BE SEALED BY STEEL TROWEL.
- UNLESS OTHERWISE NOTED:
 

A. ALL REINFORCING STEEL SHALL BE DEFORMED BARS CONFORMING TO ASTM A615, GRADE 60.

B. WELDED WIRE FABRIC SHALL CONFORM TO ASTM A185.
- SPLICING OF REINFORCEMENT IS PERMITTED ONLY AT LOCATIONS SHOWN IN THE CONTRACT DRAWINGS OR AS ACCEPTED BY THE ENGINEER. UNLESS OTHERWISE SHOWN OR NOTED REINFORCING STEEL SHALL BE SPLICED TO DEVELOP ITS FULL TENSILE CAPACITY (CLASS A) IN ACCORDANCE WITH ACI 318.
- REINFORCING BAR DEVELOPMENT LENGTHS, AS COMPUTED IN ACCORDANCE WITH ACI 318, FORM THE BASIS FOR BAR EMBEDMENT LENGTHS AND BAR SPLICED LENGTHS SHOWN IN THE DRAWINGS. APPLY APPROPRIATE MODIFICATION FACTORS FOR TOP STEEL, BAR SPACING, COVER AND THE LIKE.
- DETAILING OF REINFORCING STEEL SHALL CONFORM TO "ACI MANUAL OF STANDARD PRACTICE FOR DETAILING REINFORCED CONCRETE STRUCTURES" (ACI 315).
- ALL SLAB CONSTRUCTION SHALL BE CAST MONOLITHICALLY WITHOUT HORIZONTAL CONSTRUCTION JOINTS, UNLESS SHOWN IN THE CONTRACT DRAWINGS.
- LOCATION OF ALL CONSTRUCTION JOINTS ARE SUBJECT TO THE REQUIREMENTS OF THE CONTRACT DOCUMENTS, CONFORMANCE WITH ACI 318, AND ACCEPTANCE OF THE ENGINEER. DRAWINGS SHOWING LOCATION OF DETAILS OF THE PROPOSED CONSTRUCTION JOINTS SHALL BE SUBMITTED WITH REINFORCING STEEL PLACEMENT DRAWINGS.
- SPLICES OF WWF, AT ALL SPLICED EDGES, SHALL BE SUCH THAT THE OVERLAP MEASURED BETWEEN OUTERMOST CROSS WIRES OF EACH FABRIC SHEET IS NOT LESS THAN THE SPACING OF THE CROSS WIRE PLUS 2 INCHES, NOR LESS THAN 8".
- BAR SUPPORTS SHALL BE ALL-GALVANIZED METAL WITH PLASTIC TIPS.
- ALL REINFORCEMENT SHALL BE SECURELY TIED IN PLACE TO PREVENT DISPLACEMENT BY CONSTRUCTION TRAFFIC OR CONCRETE. TIE WIRE SHALL BE 16 GAUGE CONFORMING TO ASTM A82.
- SLAB ON GROUND
 

A. COMPACT STRUCTURAL FILL TO 95% DENSITY AND THEN PLACE 6" GRAVEL BENEATH SLAB.

B. PROVIDE VAPOR BARRIER BENEATH SLAB ON GROUND.

## GENERAL FOUNDATION NOTES:

(APPLICABLE FOR CONCRETE PADS ONLY)

- THOROUGHLY COMPACT BOTTOM OF EXCAVATIONS PRIOR TO PLACING RIGID INSULATION BARRIER. BACKFILL AND COMPACTION PROCEDURES SHALL BE DONE PER INDUSTRY STANDARDS.
- ALL REINFORCING STEEL SHALL BE ASTM A615 - GRADE 60. SECURE REINFORCING IN PLACE TO PREVENT MOVEMENT DURING CONCRETE PLACEMENT.
- PROVIDE A CLEAR COVER OF 2" FOR ALL REINFORCING STEEL. THIS REQUIREMENT SHALL BE CONSIDERED ACTUAL AND SHOULD NOT BE ADJUSTED IN THE FIELD.
- VERIFY DETAILS AND DIMENSIONS WITH SHELTER DRAWINGS. NOTIFY RISING TIDE TOWERS II OF ANY DISCREPANCIES.
- ALL WORK SHALL COMPLY WITH THE APPLICABLE CODES ENFORCED BY THE MUNICIPALITY CODE ENFORCEMENT OFFICER.
- INSULATION BARRIER PROVIDED IS FOR FROST PROTECTION IN LIEU OF STANDARD FOUNDATIONS WITH BEARING AT CODE REQUIRED FROST DEPTH AS APPROVED BY ENGINEER ONLY.

## STRUCTURAL STEEL NOTES

- STRUCTURAL STEEL SHALL CONFORM TO THE LATEST EDITION OF THE AISC "SPECIFICATION FOR THE DESIGN, FABRICATION AND ERECTION OF STRUCTURAL STEEL FOR BUILDINGS".
- STRUCTURAL STEEL ROLLED SHAPES, PLATES, AND BARS SHALL CONFORM TO THE FOLLOWING ASTM DESIGNATIONS:
 

ASTM A-572, GRADE 50	ALL W SHAPES, UNLESS NOTED OTHERWISE.
ASTM A-36	ALL OTHER ROLLED SHAPES, PLATES AND BARS UNLESS NOTED OTHERWISE.
ASTM A-500, GRADE B	HSS SECTION (SQUARE AND RECTANGULAR)
ASTM A-500, GRADE C	HSS SECTION (ROUND)
ASTM A-325, TYPE SC OR N	ALL BOLTS FOR CONNECTING STRUCTURAL MEMBERS.
ASTM A-307	ALL ANCHORS BOLTS, UNLESS NOTED OTHERWISE.
- ALL STEEL WORK SHALL BE GALVANIZED IN ACCORDANCE WITH THE SPECIFICATION ASTM A123/A123M-00 UNLESS OTHERWISE NOTED.
- ALL WELDING SHALL BE DONE USING E70XX ELECTRODES AND WELDING SHALL CONFORM TO AISC AND AWS D1.1 WHERE FILLET WELD SIZES ARE NOT SHOWN, PROVIDE THE MINIMUM SIZE PER TABLE J2.4 IN THE AISC "MANUAL OF STEEL CONSTRUCTION", 9TH EDITION. WHERE WELD LENGTH IS NOT INDICATED, USE FULL LENGTH WELD. AT THE COMPLETION OF ALL WELDING, ALL DAMAGE TO GALVANIZED COATING SHALL BE REPAIRED.
- BOLTED CONNECTIONS SHALL USE BEARING TYPE GALVANIZED ASTM A325 BOLTS (3/4" DIA.) SUPPLIED WITH A NUT AND WASHER UNDER TURNED END AND SHALL HAVE MINIMUM OF TWO BOLTS UNLESS NOTED OTHERWISE.
- NON-STRUCTURAL CONNECTIONS FOR STEEL GRATING MAY USE 5/8" DIA. GALVANIZED ASTM A 307 BOLTS UNLESS NOTED OTHERWISE.
- CONCRETE EXPANSION ANCHORS AND EPOXY ANCHORS SHALL BE INSTALLED IN ACCORDANCE WITH MANUFACTURER'S REQUIREMENTS, SPECIAL INSPECTIONS, REQUIRED BY GOVERNING CODES, SHALL BE PERFORMED IN ORDER TO MAINTAIN MANUFACTURER'S MAXIMUM ALLOWABLE LOADS. MANUFACTURER'S MINIMUM CONCRETE EDGE DISTANCE SHALL BE MAINTAINED DURING INSTALLATION.
- USE PRECAUTIONS & PROCEDURES PER AWS D1.1 WHEN WELDING GALVANIZED METALS.
- TOUCHUP ALL DAMAGED GALVANIZED STEEL WITH RISING TIDE TOWERS II APPROVED COLD ZINC, "GALVANOX", "DRY GALV", "ZINC-IT", OR APPROVED EQUIVALENT, IN ACCORDANCE WITH MANUFACTURER'S GUIDELINES. TOUCHUP DAMAGED NON GALVANIZED STEEL WITH SAME PAINT APPLIED IN SHOP OR FIELD.
- ALL PROPOSED STEEL SHALL CONFORM TO HIGH STRENGTH STEEL MATERIALS, ASTM A36 WITH A MINIMUM STRENGTH OF 36 KSI.
- ALL EXISTING BEAM AND COLUMN DIMENSIONS SHALL BE FIELD VERIFY BY CONTRACTOR PRIOR TO FABRICATION. ANY DISCREPANCIES BETWEEN EXISTING CONDITIONS AND THOSE SHOWN SHALL BE REPORTED TO DEWBERRY ENGINEER IMMEDIATELY.
- CONTRACTOR TO MAKE ALL NECESSARY PRECAUTIONS AND SECURE ALL PERMITS REQUIRED FOR WELDING ON THE ROOF.

## EROSION AND SEDIMENT CONTROL PLAN:

THIS PLAN HAS BEEN DEVELOPED TO PROVIDE A STRATEGY FOR CONTROLLING SOIL EROSION AND SEDIMENTATION DURING AND AFTER CONSTRUCTION OF THE PROPOSED DEVELOPMENT.

THE EQUIPMENT ANTICIPATED TO BE USED FOR THE CONSTRUCTION INCLUDES THE FOLLOWING: BACKHOES, BULLDOZERS, LOADERS, TRUCKS, CRANES, COMPACTORS, AND GRADERS. THE FOLLOWING MEASURES WILL BE UNDERTAKEN TO PROVIDE MAXIMUM PROTECTION TO THE SOIL, WATER, AND ADJUTING LANDS:

- PRIOR TO GRUBBING OR ANY EARTHMOVING OPERATION, SILTATION FENCE WILL BE INSTALLED ACROSS THE SLOPE ON THE CONTOUR AT THE DOWNHILL LIMIT OF THE WORK AS PROTECTION AGAINST CONSTRUCTION RELATED EROSION.
- STONE CHECK DAMS WILL BE INSTALLED IN THE DRAINAGE SWALES TO PREVENT EROSION PRIOR TO THE STABILIZATION OF THE CHANNELS. EROSION CONTROL MESH WILL ALSO BE INSTALLED IN ALL DITCH TO BE REVEGETATED.
- ALL DISTURBED AREAS WILL BE MULCHED FOR EROSION CONTROL WITHIN 7 CALENDAR DAYS FOLLOWING THE COMPLETION OF ANY SOIL DISTURBANCE, AND PRIOR TO ANY STORM EVENT. PERMANENT SOIL EROSION CONTROL MEASURES FOR ALL SLOPES, CHANNELS, DITCHES, OR ANY UNDISTURBED LAND AREA WILL BE COMPLETED WITHIN FIFTEEN CALENDAR DAYS AFTER FINAL GRADING HAS BEEN COMPLETED. WHEN IT IS NOT POSSIBLE OR PRACTICAL TO PERMANENTLY STABILIZE DISTURBED LAND, TEMPORARY EROSION CONTROL MEASURES WILL BE IMPLEMENTED WITHIN THIRTY CALENDAR DAYS OF EXPOSURE OF SOIL.
- ANY EXPOSED SLOPES GREATER THAN 3:1 AND NEWLY CONSTRUCTED DRAINAGE SWALES WILL BE STABILIZED WITH EROSION CONTROL MESH TO PREVENT EROSION DURING CONSTRUCTION AND TO FACILITATE REVEGETATION AFTER LOAMING AND SEEDING.
- TO PROVIDE PROTECTION AGAINST EROSION, RIPRAP WILL BE PLACED AT ALL STORM DRAIN INLETS AND OUTLETS AS SHOWN ON THE ATTACHED DRAWINGS.
- IN AREAS OF CONSTRUCTION DEWATERING, ISOLATED SETTLEMENT TRAPS WILL BE CONSTRUCTED ADJACENT TO THE ACTIVITY. WATER WILL BE PUMPED FROM THE EXCAVATIONS TO THESE DEPRESSION AREAS FOR SEDIMENT REMOVAL. ADDITIONAL SEDIMENTATION PROTECTION WILL BE PROVIDED BY THE INSTALLATION OF HAYBALE BARRIERS BETWEEN THE BASINS AND THE RECEIVING DRAINAGE COURSE.
- NATIVE TOPSOIL SHALL BE SAVED, STOCKPILED, MULCHED, AND REUSED AS MUCH AS POSSIBLE ON THE SITE. SILTATION FENCE SHALL BE INSTALLED AT THE BASE OF STOCKPILES AT THE DOWNHILL LIMIT TO PROTECT AGAINST EROSION. STOCKPILES WILL BE STABILIZED BY SEEDING AND MULCHING UPON FORMATION OF THE PILES. UPHILL OF THE STOCKPILES, STABILIZED DITCHES AND/OR BERMS WILL BE CONSTRUCTED TO DIVERT STORMWATER RUNOFF AWAY FROM THE PILES.
- ALL SILTATION FENCE AND HAY BALE BARRIERS WILL BE INSPECTED BY THE CONTRACTOR ON A WEEKLY BASIS OR FOLLOWING ANY SIGNIFICANT RAINFALL (1/2 INCH OR MORE) OR SNOWMELT. ALL DAMAGED EROSION CONTROL DEVICES WILL BE REPAIRED AND/OR REPLACED IMMEDIATELY. TRAPPED SEDIMENT WILL BE REMOVED BEFORE IT HAS ACCUMULATED TO ONE-HALF OF THE INSTALLED SILTATION FENCE OR HAY BALE BARRIER HEIGHT. DEVICES NO LONGER SERVICEABLE DUE TO SEDIMENT ACCUMULATION WILL ALSO BE REPAIRED AND/OR REPLACED AS NECESSARY. WITHIN 30 DAYS OF FINAL STABILIZATION OF THE SITE, ANY SILT FENCE OR EROSION CONTROL MUST BE REMOVED.
- IF FINAL SEEDING OF THE UNDISTURBED AREAS IS NOT COMPLETED BY SEPTEMBER 15 OF THE YEAR OF CONSTRUCTION, THEN WITHIN THE NEXT 10 CALENDAR DAYS THESE AREAS WILL BE GRADED AND SMOOTHED, THEN SEEDED TO A WINTER COVER CROP OF RYE AT A RATE OF 3 LBS. PER 1,000 SQ. FT. THE FOLLOWING WILL BE INCORPORATED INTO THE SOIL PRIOR TO RYE SEEDING. GROUND LIMESTONE AT A RATE OF 130 LBS. PER 1,000 SQ. FT., FOLLOWED BY A 10-10 FERTILIZER AT A RATE OF 14 LBS. PER 1,000 SQ. FT. HAY MULCH WILL BE APPLIED AT A RATE OF 100 LBS. PER 1,000 SQ. FT. FOLLOWING SEEDING. IF THE RYE SEEDING CANNOT BE COMPLETED BY OCTOBER 1, THEN ON THAT DATE HAY MULCH SHALL BE APPLIED AT THE RATE OF 2 TONS PER ACRE TO PROVIDE WINTER PROTECTION. IF RYE DOES NOT MAKE ADEQUATE GROWTH BY NOVEMBER 5, THEN ON THAT DATE, HAY MULCH SHALL BE APPLIED AT THE RATE OF 100 LBS. PER 1,000 SQ. FT. A SUITABLE BINDER SUCH AS CURASOL OR RMB PLUS SHALL BE USED ON HAY MULCH FOR WIND CONTROL. BIODEGRADABLE NETTING WILL BE INSTALLED ON STEEP SLOPES (3:1 AND STEEPER) AND ON AREAS OF CONCENTRATED FLOWS.
- INTERCEPTED SEDIMENT WILL BE RETURNED TO THE SITE AND INCORPORATED INTO THE PROJECT AREA.
- SHOULD CONSTRUCTION OCCUR AFTER NOVEMBER 15, ADDITIONAL EROSION CONTROL METHODS WILL BE IMPLEMENTED. ALL DISTURBED AREAS WILL BE MINIMIZED AS MUCH AS POSSIBLE. PRIOR TO FREEZING, ADDITIONAL EROSION CONTROL DEVICES WILL BE INSTALLED AS APPROPRIATE INSPECTION OF THESE EROSION CONTROL ITEMS WILL BE CONSTANT, WITH PARTICULAR ATTENTION PAID TO WEATHER PREDICTIONS TO ENSURE THAT THESE MEASURES ARE PROPERLY IN PLACE TO HANDLE LARGE AMOUNTS OF RUNOFF FROM HEAVY RAINS OR THAWS.

**RISING TIDE II**  
TOWERS II  
5 MILK STREET  
SUITE 110  
PORTLAND, ME 04101

**POWNA, VT**  
**SITE #: RTT2-01**

## CONSTRUCTION DRAWINGS

C	04/23/25	FOR COMMENT
B	01/08/25	FOR COMMENT
A	11/14/24	FOR COMMENT

**Dewberry**<sup>®</sup>  
Dewberry Engineers Inc.  
99 SUMMER STREET  
SUITE 700  
BOSTON, MA 02110  
PHONE: 617.695.3400  
FAX: 617.695.3310

DRAWN BY: GMT

REVIEWED BY: DAS

CHECKED BY: BBR

PROJECT NUMBER: 50170469

JOB NUMBER: 50184159

SITE ADDRESS

127 CROW HILL ROAD  
POWNA, VT 05261

SHEET TITLE

GENERAL NOTES

SHEET NUMBER

G-1

# RISEING TIDE II TOWERS II

5 MILK STREET  
SUITE 110  
PORTLAND, ME 04101

**POWNAI, VT  
SITE #: RTT2-01**

## CONSTRUCTION DRAWINGS

REV	DATE	DESCRIPTION
C	04/23/25	FOR COMMENT
B	01/08/25	FOR COMMENT
A	11/14/24	FOR COMMENT



**Dewberry Engineers Inc.**  
99 SUMMER STREET  
SUITE 700  
BOSTON, MA 02110  
PHONE: 617.695.3400  
FAX: 617.695.3310

DRAWN BY: GMT

REVIEWED BY: DAS

CHECKED BY: BBR

PROJECT NUMBER: 50170469

JOB NUMBER: 50184159

SITE ADDRESS

127 CROW HILL ROAD  
POWNAI, VT 05261

SHEET TITLE

ABUTTERS PLAN

SHEET NUMBER

Z-1

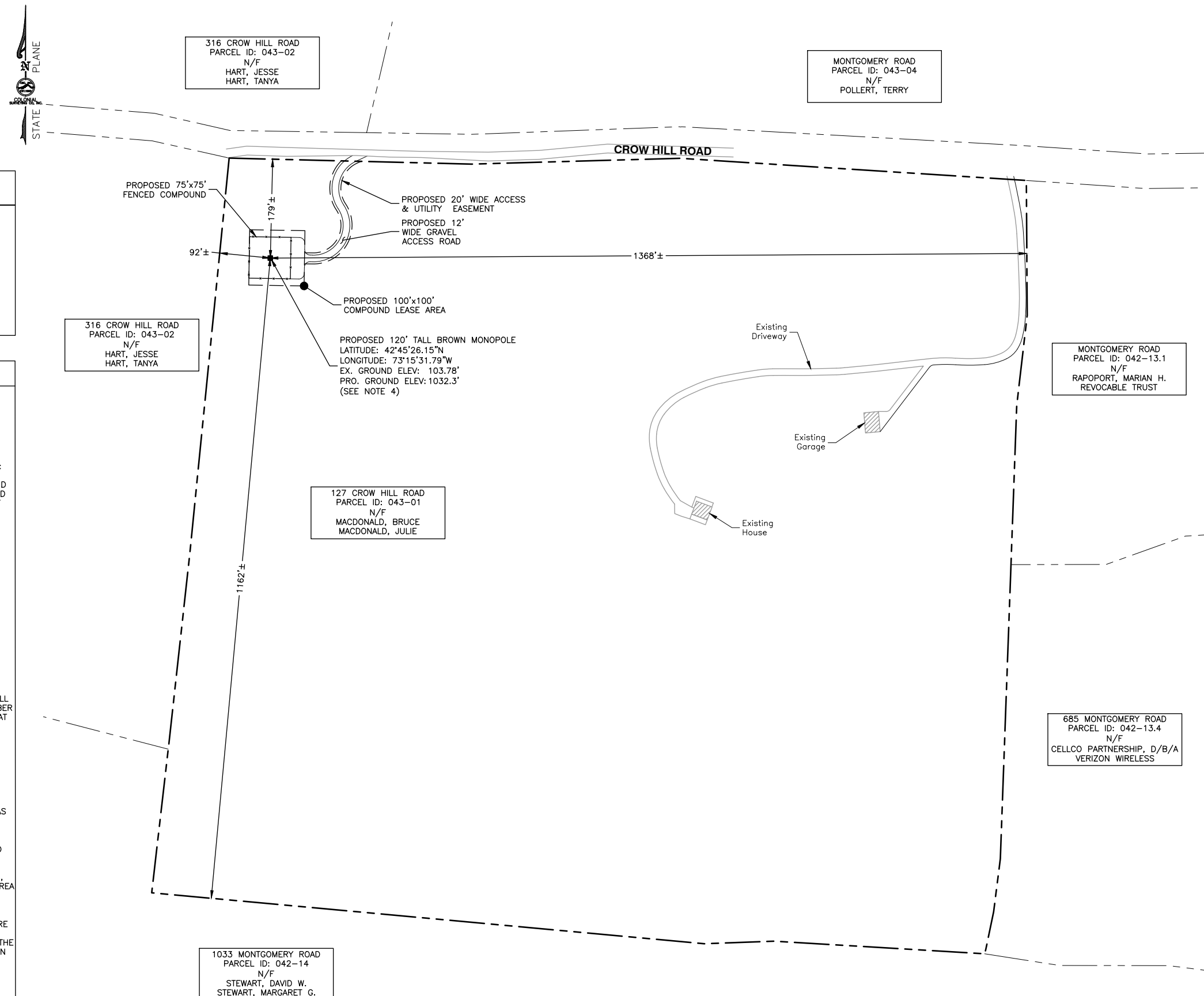

## LEGEND

- LOCUS PROPERTY LINE
- ABUTTER PROPERTY LINE
- PROPOSED EASEMENT/LEASE AREA
- PROPOSED FENCED COMPOUND
- PROPOSED EDGE OF ACCESS ROAD
- EXISTING EDGE OF ROAD/DRIVEWAY

## GENERAL NOTES

1. FIELD SURVEY DATE: OCTOBER, 2024
2. VERTICAL DATUM: NORTH AMERICAN VERTICAL DATUM OF 1988 (NAVD88)
3. HORIZONTAL DATUM: VT STATE PLANE COORDINATE SYSTEM (SPCS), NAD83 (2011) EPOCH 2010.0000. COORDINATES & DISTANCES ARE GRID DISTANCES, WHICH ARE DERIVED FROM GROUND MEASUREMENTS USING A COMBINED SCALE FACTOR OF 0.99996748 AT BENCHMARK.
4. CENTER PROPOSED TOWER: 42°45'26.15"N, 73°15'31.79"W
5. OWNER: BRUCE & JULIE MACDONALD  
719 NW HILL ROAD  
POWNAI, VT 05261
6. SITE NAME: POWNAI, VT
7. SITE NUMBER: RTT2-01
8. SITE ADDRESS: 127 CROW HILL ROAD  
POWNAI, VT 05261
9. JURISDICTION: STATE OF VT
10. DEED REFERENCE: BOOK 114 / PAGE 391.
11. LOCUS PLAN: BOUNDARY SURVEY, LANDS OF BARBARA HORNSBY, 127 CROW HILL ROAD, POWNAI, VERMONT, DECEMBER 2010, RECORDED MAY 11, 2011 AT MAP SLIDE #134
12. ABUTTERS INFORMATION TAKEN FROM TOWN TAX DATA.
13. GRID NORTH BASED ON GPS.  
GRID NORTH TO MAGNETIC NORTH 2024 IS: -13°17'50".
14. ELEVATIONS AND COORDINATES FROM GPS LOCATIONS.
15. ALL UNDERGROUND UTILITY INFORMATION PRESENTED HEREON WAS DETERMINED FROM SURFACE EVIDENCE AND PLANS OF RECORD. ALL UNDERGROUND UTILITIES SHOULD BE LOCATED IN THE FIELD PRIOR TO COMMENCEMENT OF ALL SITE WORK. CALL DIGSAFE 1(800) 322-4844 A MINIMUM OF 72 HOURS PRIOR TO PLANNED ACTIVITY.
16. ACCORDING TO FEDERAL EMERGENCY MANAGEMENT AGENCY MAPS, THE PROPOSED TOWER ON THIS PROPERTY IS LOCATED IN AN AREA DESIGNATED AS ZONE X. NOT WITHIN THE 100 YEAR FLOOD BOUNDARY. PANEL NO. 50003C0494D EFFECTIVE 12/02/2015.
17. THE BEARINGS, DISTANCES, AND PHYSICAL FEATURES SHOWN HERE WERE CALCULATED, MEASURED, AND LOCATED FROM ON-THE-GROUND FIELD SURVEYS CONDUCTED OCTOBER, 2024. THE SURVEYS WERE CONDUCTED USING AN ELECTRONIC TOTAL STATION INSTRUMENT AND JAVAD GNSS TRIUMPH T3 AND AN TRIUMPH LS PLUS. BASE STATION AND ROVER GPS RECEIVERS. BOTH STATIC AND RTK SOLUTIONS WERE USED TO ENSURE THE HIGHEST POSSIBLE ACCURACY.

## ABUTTERS PLAN

SCALE: 1"=160' FOR 11"x17"  
1"=80' FOR 22"x34"

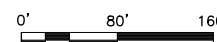

1

**LEGEND**

	PROPOSED EASEMENT/LEASE AREA
	LOCUS PROPERTY LINE
	ABUTTER PROPERTY LINE
	PROPOSED FENCED COMPOUND
	PROPOSED ROAD
	PROPOSED ROAD CENTERLINE
	EXISTING TREELINE
	PROPOSED CLEARING
	EXISTING EDGE OF ROAD
	PROPOSED EROSION CONTROL
	EXISTING OVERHEAD WIRES
	PROPOSED OVERHEAD WIRES
	PROPOSED UTILITY POLE
	EXISTING UTILITY POLE
	PROPOSED SPOT GRADE

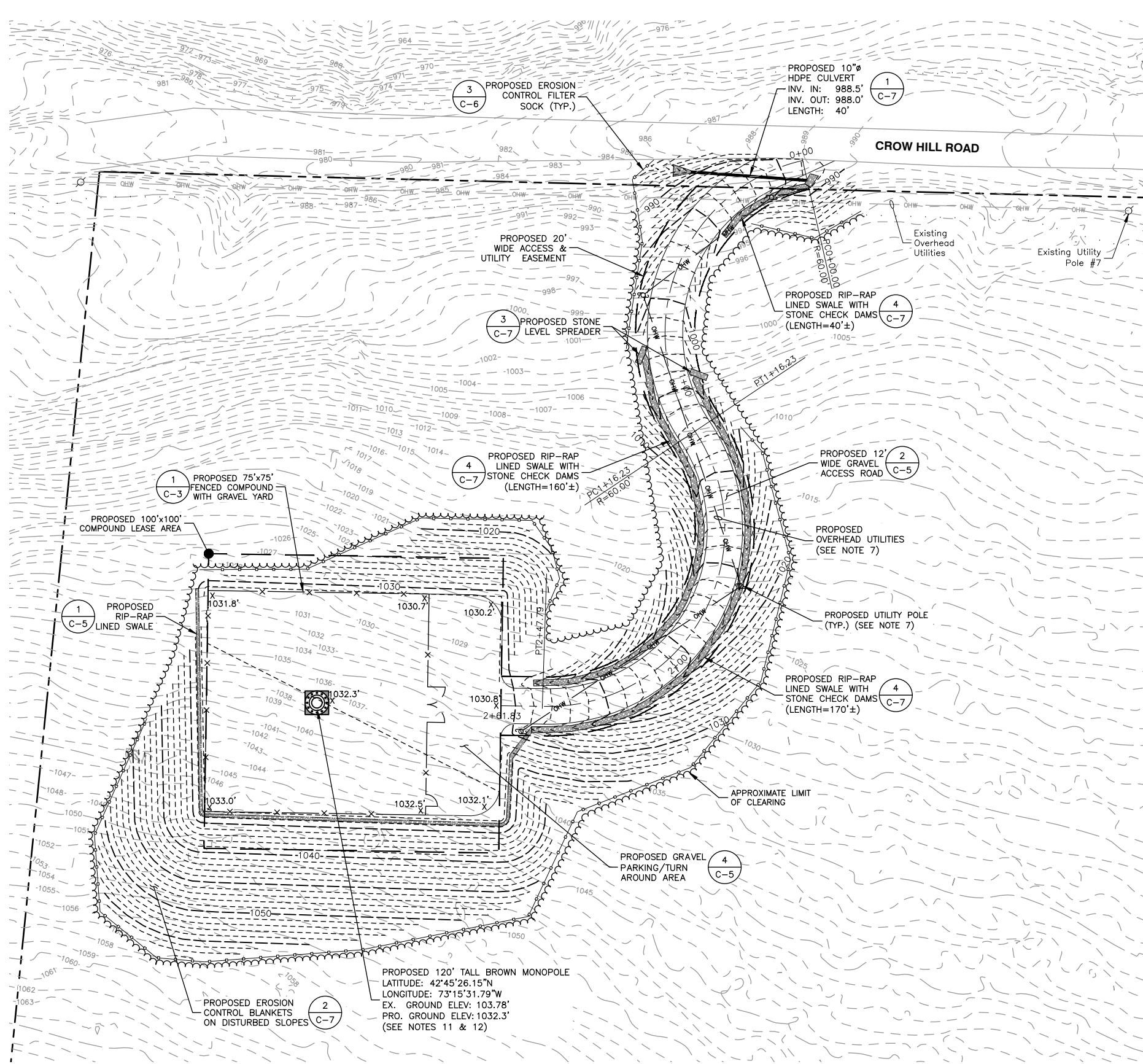

- NOTES:**
- SOME EXISTING INFORMATION IS NOT SHOWN FOR CLARITY.
  - TOTAL TEMPORARY AREA TO BE DISTURBED: 25,750± SQ. FT. (0.59± ACRES)
  - TOTAL PROPOSED IMPERVIOUS AREA/PERMANENT AREA TO BE DISTURBED (INCLUDES GRAVEL ACCESS ROAD, COMPOUND, & PARKING AREA): 10,662± SQ. FT. (0.24± ACRES). THIS REPRESENTS 0.51% OF THE TOTAL PARCEL AREA.  
TOTAL EXISTING IMPERVIOUS SURFACES (INCLUDES EXISTING DRIVEWAY, HOUSE, & GARAGE): 18,094± SQ. FT. (0.42± ACRES)  
TOTAL FINAL IMPERVIOUS AREA (EXISTING + PROPOSED): 28,756 SQ. FT. (0.66 ACRES)
  - TOTAL LENGTH OF PROPOSED ACCESS ROAD: 262'±.
  - TOTAL AREA ASSOCIATED WITH WIRELESS FACILITY INCLUDING ACCESS & UTILITY EASEMENT AND COMPOUND LEASE AREA IS APPROXIMATELY 14,796 S.F. (0.34 ACRES).
  - LOAM & SEED ALL DISTURBED AREAS WITHIN 7 CALENDAR DAYS AFTER ALL SITE & TRENCH WORK HAS BEEN COMPLETED.
  - UTILITIES SHALL EXTEND OVERHEAD WITHIN PROPOSED EASEMENT. FINAL PLACEMENT OF NEW UTILITY POLES BASED ON FIELD CONDITIONS & UTILITY CO. APPROVAL.
  - DEWBERRY ENGINEERS INC. & COLONIAL SURVEY, INC. HAVE NOT LOCATED ANY UNDERGROUND UTILITIES. ALWAYS CALL DIG SAFE TO MARK OUT UNDERGROUND UTILITIES PRIOR TO ANY EXCAVATION ACTIVITIES.
  - THE PROJECT WILL COMPLY WITH THE LOW RISK HANDBOOK FOR EROSION PREVENTION AND SEDIMENT CONTROL BY THE VERMONT DEPARTMENT OF ENVIRONMENTAL CONSERVATION.
  - ALL WORK SHALL CONFORM TO ALL CURRENT APPLICABLE VT STATE BUILDING CODE, NATIONAL ELECTRIC CODE (NEC 2017), ANSI/EIA/TIA-222.
  - DEWBERRY ENGINEERS INC. HAS NOT BEEN PROVIDED WITH TOWER OR FOUNDATION DESIGNS. FINAL TOWER & FOUNDATION DESIGNS TO BE COMPLETED BY SABRE PRIOR TO CONSTRUCTION & TOWER FABRICATION.
  - FINAL TOWER HEIGHT IS DEPENDENT ON FOUNDATION ELEVATION ABOVE GROUND LEVEL. CONSTRUCTION MANAGER TO REVIEW FINAL FOUNDATION HEIGHT ABOVE FINISHED GRADE & REDUCE THE TOWER HEIGHT ACCORDINGLY TO ACHIEVE FINAL ELEVATION SHOWN.

**SITE & GRADING PLAN**  
 SCALE: 1"=40' FOR 11"x17"  
 1"=20' FOR 22"x34"  
 0' 20' 40'

**RIISING TIDE II  
TOWERS II**

5 MILK STREET  
SUITE 110  
PORTLAND, ME 04101

**POWNAI, VT  
SITE #: RTT2-01**

**CONSTRUCTION DRAWINGS**

C	04/23/25	FOR COMMENT
B	01/08/25	FOR COMMENT
A	11/14/24	FOR COMMENT

**Dewberry®**  
 Dewberry Engineers Inc.  
 99 SUMMER STREET  
 SUITE 700  
 BOSTON, MA 02110  
 PHONE: 617.695.3400  
 FAX: 617.695.3310



DRAWN BY:	GMT
REVIEWED BY:	DAS
CHECKED BY:	BBR
PROJECT NUMBER:	50170469
JOB NUMBER:	50184159
SITE ADDRESS	

127 CROW HILL ROAD  
POWNAI, VT 05261

SHEET TITLE	PROPOSED SITE & GRADING PLAN
SHEET NUMBER	

C-1

# RISING TIDE II TOWERS II

5 MILK STREET  
SUITE 110  
PORTLAND, ME 04101

**POWNA, VT  
SITE #: RTT2-01**

### CONSTRUCTION DRAWINGS

C	04/23/25	FOR COMMENT
B	01/08/25	FOR COMMENT
A	11/14/24	FOR COMMENT



**Dewberry Engineers Inc.**  
99 SUMMER STREET  
SUITE 700  
BOSTON, MA 02110  
PHONE: 617.695.3400  
FAX: 617.695.3310

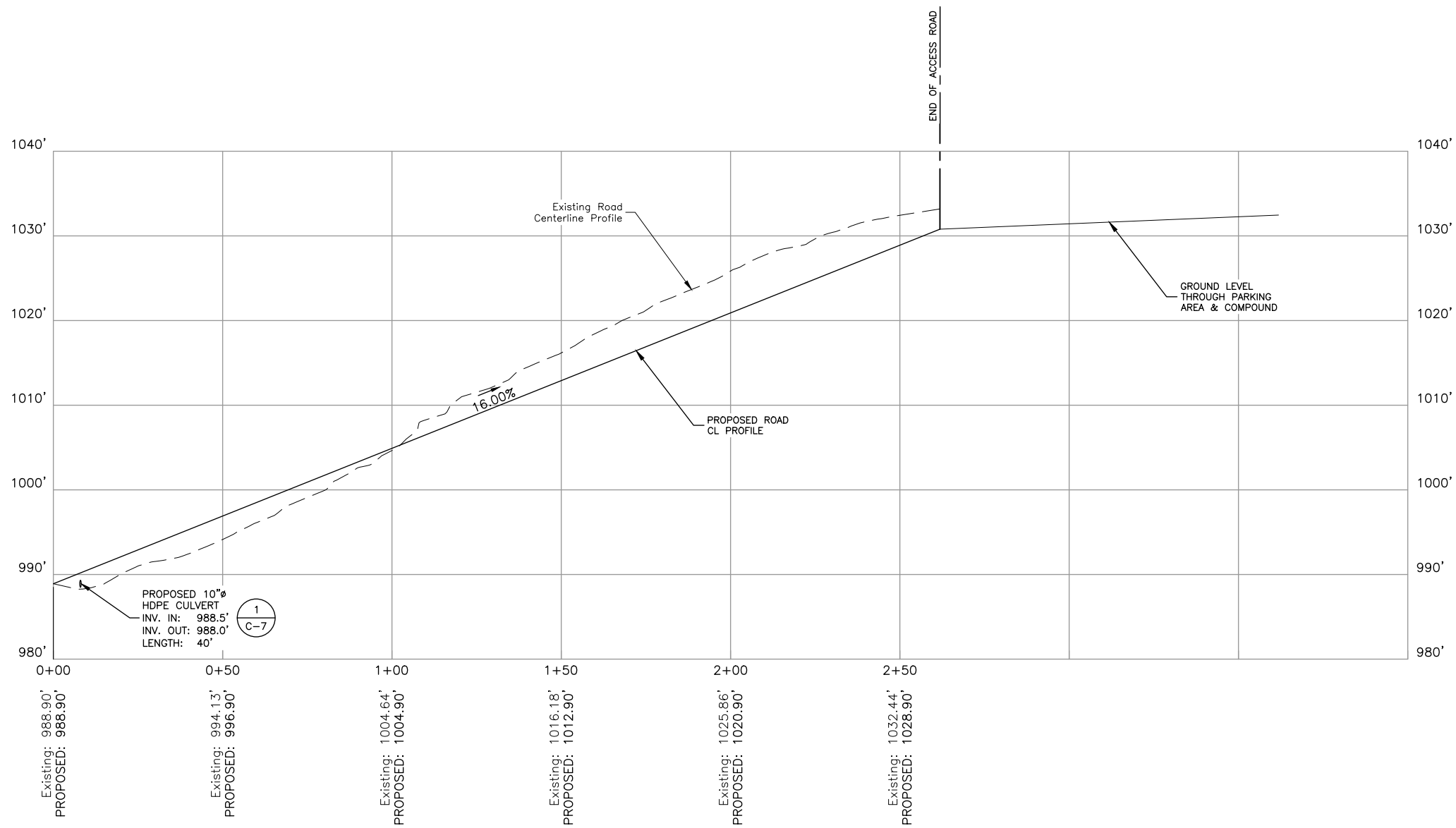

### ACCESS ROAD PROFILE

HORIZONTAL SCALE: 1"=40' FOR 11"x17"  
1"=20' FOR 22"x34"  
VERTICAL SCALE: 1"=16' FOR 11"x17"  
1"=8' FOR 22"x34"



DRAWN BY: GMT

REVIEWED BY: DAS

CHECKED BY: BBR

PROJECT NUMBER: 50170469

JOB NUMBER: 50184159

SITE ADDRESS

127 CROW HILL ROAD  
POWNA, VT 05261

SHEET TITLE

ACCESS ROAD PROFILE

SHEET NUMBER

C-2



# RISEING TIDE II TOWERS II

5 MILK STREET  
SUITE 110  
PORTLAND, ME 04101

**POWNAI, VT  
SITE #: RTT2-01**

**CONSTRUCTION DRAWINGS**

C	04/23/25	FOR COMMENT
B	01/08/25	FOR COMMENT
A	11/14/24	FOR COMMENT



**Dewberry Engineers Inc.**  
99 SUMMER STREET  
SUITE 700  
BOSTON, MA 02110  
PHONE: 617.695.3400  
FAX: 617.695.3310

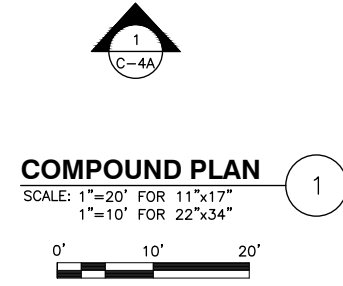
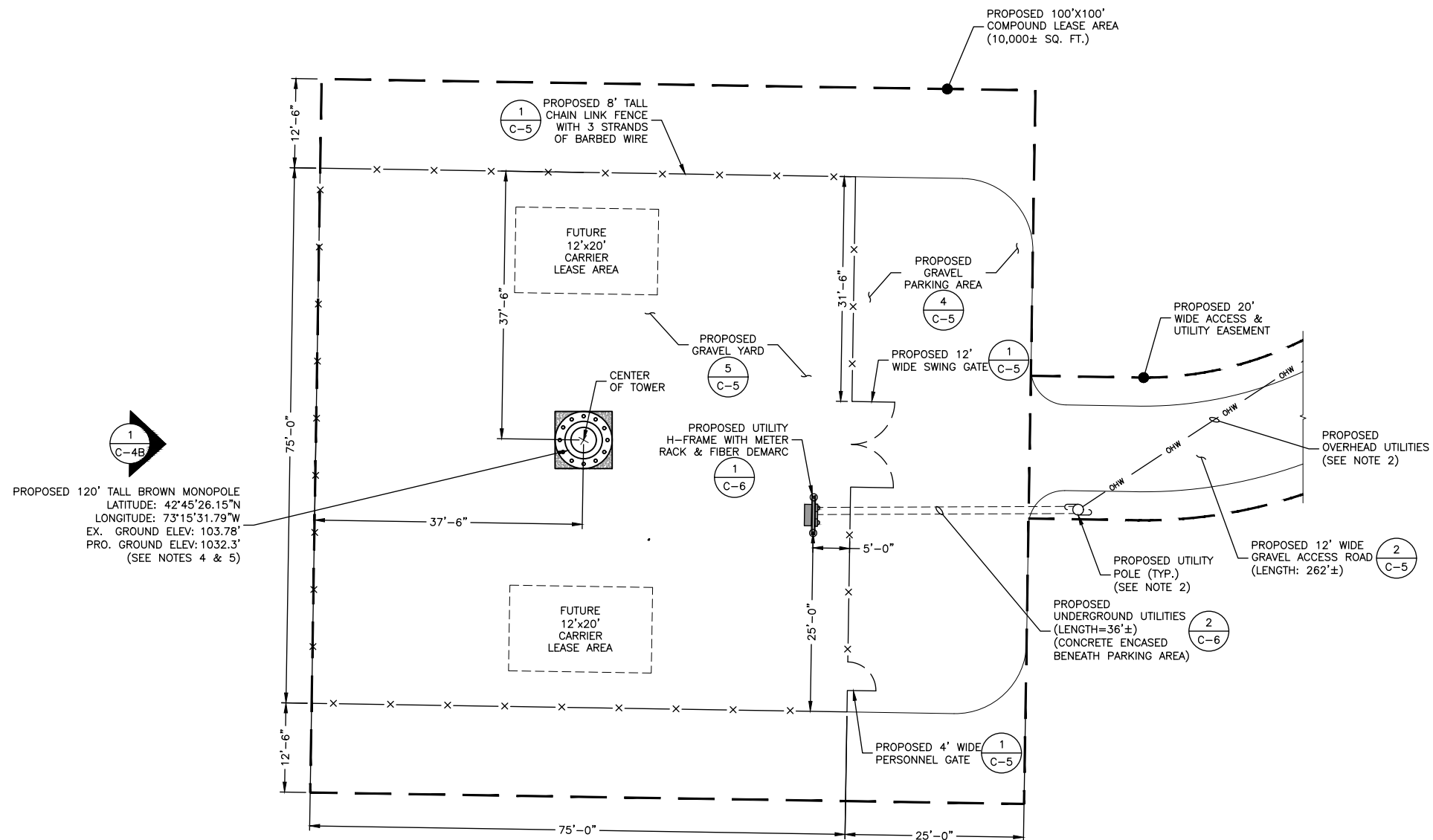

- NOTES:**
- SOME EXISTING & PROPOSED INFORMATION IS NOT SHOWN FOR CLARITY.
  - UTILITIES SHALL EXTEND OVERHEAD WITHIN PROPOSED EASEMENT. FINAL PLACEMENT OF NEW UTILITY POLES BASED ON FIELD CONDITIONS & UTILITY CO. APPROVAL.
  - ALL WORK SHALL CONFORM TO ALL CURRENT APPLICABLE VT STATE BUILDING CODE, NATIONAL ELECTRIC CODE (NEC 2017), ANSI/EIA/TIA-222.
  - DEWBERRY ENGINEERS INC. HAS NOT BEEN PROVIDED WITH TOWER OR FOUNDATION DESIGNS. FINAL TOWER & FOUNDATION DESIGNS TO BE COMPLETED BY SABRE PRIOR TO CONSTRUCTION & TOWER FABRICATION.
  - FINAL TOWER HEIGHT IS DEPENDENT ON FOUNDATION ELEVATION ABOVE GROUND LEVEL. CONSTRUCTION MANAGER TO REVIEW FINAL FOUNDATION HEIGHT ABOVE FINISHED GRADE & REDUCE THE TOWER HEIGHT ACCORDINGLY TO ACHIEVE FINAL ELEVATION SHOWN.

DRAWN BY:	GMT
REVIEWED BY:	DAS
CHECKED BY:	BBR
PROJECT NUMBER:	50170469
JOB NUMBER:	50184159
SITE ADDRESS	

127 CROW HILL ROAD  
POWNAI, VT 05261

SHEET TITLE	PROPOSED COMPOUND PLAN
SHEET NUMBER	

C-3

# RISING TIDE II TOWERS II

5 MILK STREET  
SUITE 110  
PORTLAND, ME 04101

**POWNA, VT  
SITE #: RTT2-01**

## CONSTRUCTION DRAWINGS

C	04/23/25	FOR COMMENT
B	01/08/25	FOR COMMENT
A	11/14/24	FOR COMMENT



Dewberry Engineers Inc.  
99 SUMMER STREET  
SUITE 700  
BOSTON, MA 02110  
PHONE: 617.695.3400  
FAX: 617.695.3310

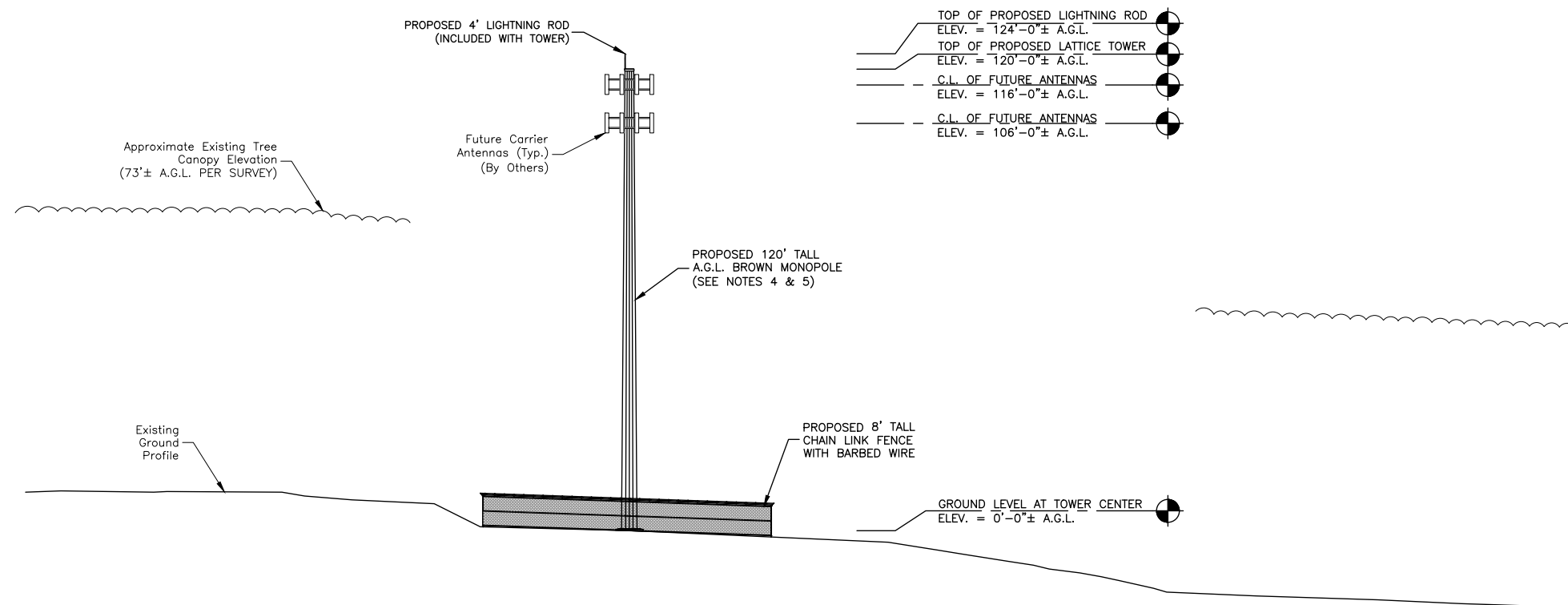

### NORTH ELEVATION

SCALE: 1"=20' FOR 11"x17"  
1"=10' FOR 22"x34"

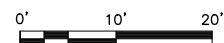

#### NOTES:

- SOME PROPOSED INFORMATION IS NOT SHOWN FOR CLARITY.
- A.G.L. - ABOVE GRADE LEVEL  
C.L. - CENTERLINE.
- ALL WORK SHALL CONFORM TO ALL CURRENT APPLICABLE VT STATE BUILDING CODE, NATIONAL ELECTRIC CODE (NEC 2017), ANSI/EIA/TIA-222.
- DEWBERRY ENGINEERS INC. HAS NOT BEEN PROVIDED WITH TOWER OR FOUNDATION DESIGNS. FINAL TOWER & FOUNDATION DESIGNS TO BE COMPLETED BY SABRE PRIOR TO CONSTRUCTION & TOWER FABRICATION.
- FINAL TOWER HEIGHT IS DEPENDENT ON FOUNDATION ELEVATION ABOVE GROUND LEVEL. CONSTRUCTION MANAGER TO REVIEW FINAL FOUNDATION HEIGHT ABOVE FINISHED GRADE & REDUCE THE TOWER HEIGHT ACCORDINGLY TO ACHIEVE FINAL ELEVATION SHOWN.

DRAWN BY: GMT

REVIEWED BY: DAS

CHECKED BY: BBR

PROJECT NUMBER: 50170469

JOB NUMBER: 50184159

SITE ADDRESS

127 CROW HILL ROAD  
POWNA, VT 05261

SHEET TITLE

PROPOSED  
NORTH ELEVATION

SHEET NUMBER

C-4A

# RISING TIDE II TOWERS II

5 MILK STREET  
SUITE 110  
PORTLAND, ME 04101

**POWNA, VT  
SITE #: RTT2-01**

## CONSTRUCTION DRAWINGS

C	04/23/25	FOR COMMENT
B	01/08/25	FOR COMMENT
A	11/14/24	FOR COMMENT



Dewberry Engineers Inc.  
99 SUMMER STREET  
SUITE 700  
BOSTON, MA 02110  
PHONE: 617.695.3400  
FAX: 617.695.3310

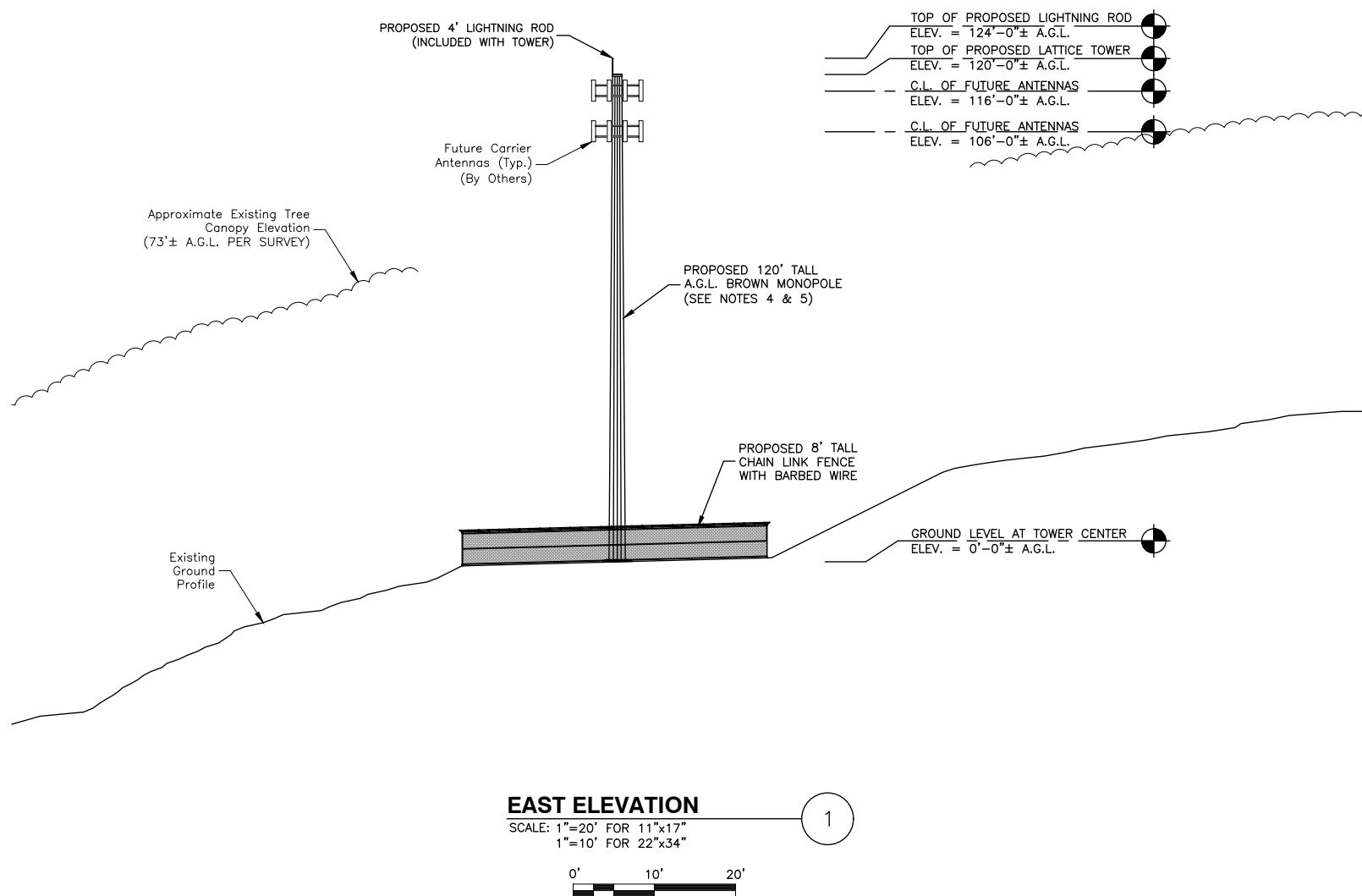

### EAST ELEVATION

SCALE: 1"=20' FOR 11"x17"  
1"=10' FOR 22"x34"

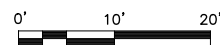

#### NOTES:

- SOME PROPOSED INFORMATION IS NOT SHOWN FOR CLARITY.
- A.G.L. - ABOVE GRADE LEVEL  
C.L. - CENTERLINE.
- ALL WORK SHALL CONFORM TO ALL CURRENT APPLICABLE VT STATE BUILDING CODE, NATIONAL ELECTRIC CODE (NEC 2017), ANSI/EIA/TIA-222.
- DEWBERRY ENGINEERS INC. HAS NOT BEEN PROVIDED WITH TOWER OR FOUNDATION DESIGNS. FINAL TOWER & FOUNDATION DESIGNS TO BE COMPLETED BY SABRE PRIOR TO CONSTRUCTION & TOWER FABRICATION.
- FINAL TOWER HEIGHT IS DEPENDENT ON FOUNDATION ELEVATION ABOVE GROUND LEVEL. CONSTRUCTION MANAGER TO REVIEW FINAL FOUNDATION HEIGHT ABOVE FINISHED GRADE & REDUCE THE TOWER HEIGHT ACCORDINGLY TO ACHIEVE FINAL ELEVATION SHOWN.

DRAWN BY: GMT

REVIEWED BY: DAS

CHECKED BY: BBR

PROJECT NUMBER: 50170469

JOB NUMBER: 50184159

SITE ADDRESS

127 CROW HILL ROAD  
POWNA, VT 05261

SHEET TITLE

PROPOSED  
EAST ELEVATION

SHEET NUMBER

C-4B

# RISEING TIDE II TOWERS II

5 MILK STREET  
SUITE 110  
PORTLAND, ME 04101

**POWNAI, VT  
SITE #: RTT2-01**

## CONSTRUCTION DRAWINGS

C	04/23/25	FOR COMMENT
B	01/08/25	FOR COMMENT
A	11/14/24	FOR COMMENT



**Dewberry Engineers Inc.**  
99 SUMMER STREET  
SUITE 700  
BOSTON, MA 02110  
PHONE: 617.695.3400  
FAX: 617.695.3310

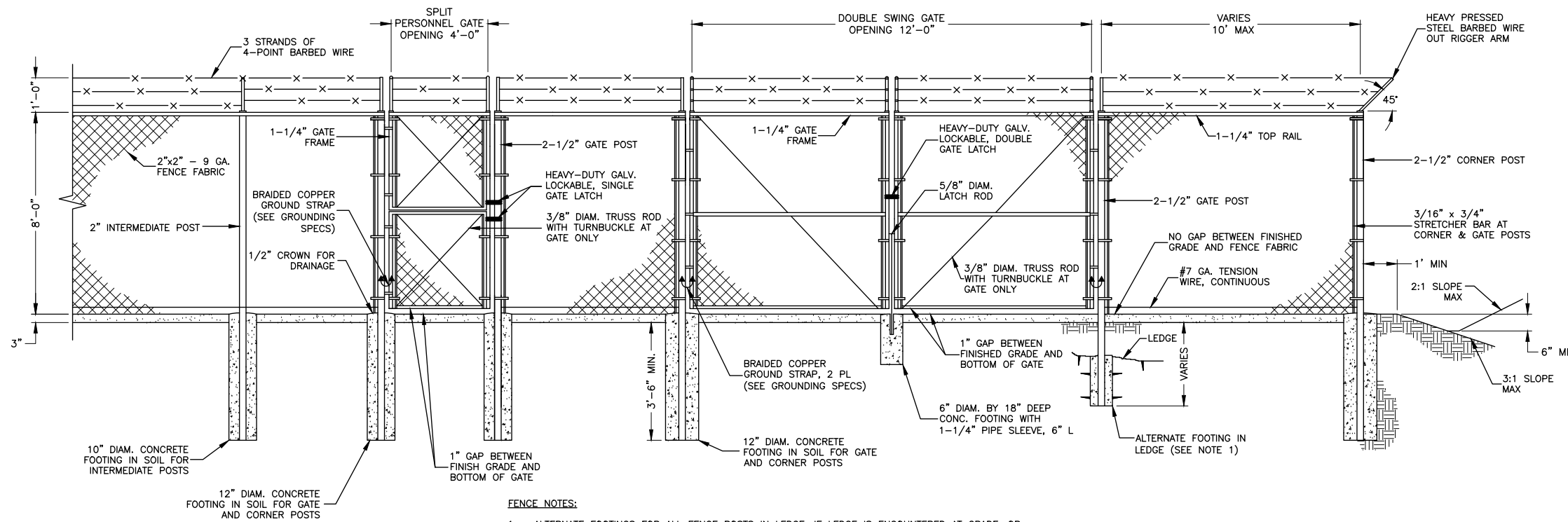

### FENCE NOTES:

- ALTERNATE FOOTINGS FOR ALL FENCE POSTS IN LEDGE: IF LEDGE IS ENCOUNTERED AT GRADE, OR AT A DEPTH SHALLOWER THAN 3'-6", CORE DRILL AN 8" DIA HOLE 18" INTO THE LEDGE. CENTER POST IN THE HOLE AND FILL WITH CONCRETE OR GROUT. IF LEDGE IS BELOW FINISHED GRADE, COAT BACKFILLED SECTION OF POST WITH COAL TAR, AND BACKFILL WITH WELL-DRAINING GRAVEL.
- ATTACH EACH GATE WITH 1-1/2 PAIR OF NON-LIFT-OFF TYPE, MALLEABLE IRON OR FORGING, PIN-TYPE HINGES. ASSEMBLIES SHALL ALLOW FOR 180° OF GATE TRAVEL.
- INSTALL SWALE AROUND COMPOUND (MIN. DEPTH: 6") TO ALLOW FOR DRAINAGE.

## FENCE AND ACCESS GATES

SCALE: N.T.S.

1

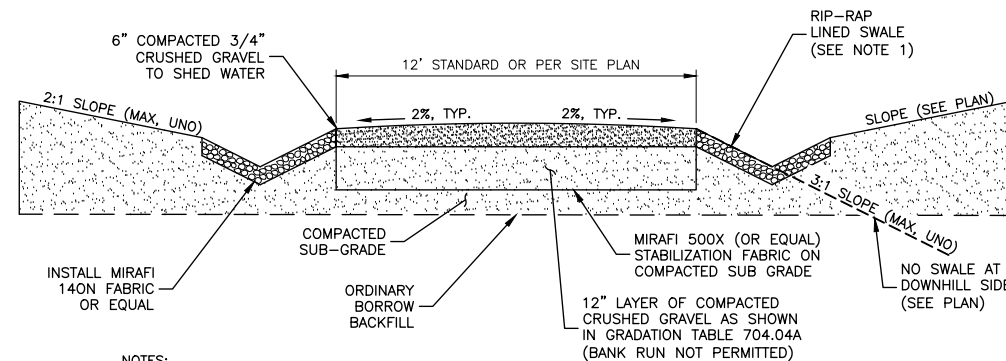

### NOTES:

- LINE SWALE WITH RIP-RAP 6" MIN. DIA. LOCATION AS NOTED ON PLANS.
- SUBGRADE AND FILL SHALL CONSIST OF CLEAN SOIL. NO DELETERIOUS MATERIALS OR ORGANICS TO BE USED.
- REMOVE MINIMUM OF 12" OF TOP SOIL AND ORGANICS BEFORE COMMENCING ACCESS ROAD.
- THE EDGE OF GRAVEL ROADS MUST BE GRADED SUCH THAT WATER CAN FREELY FLOW TO THE ABUTTING DITCH/SWALE OR GROUND SURFACE. GRAVEL THAT FALLS INTO DRAINAGE DITCHES AND SWALES MUST BE REMOVED.

## ROAD CROSS SECTION WITH SWALES

SCALE: N.T.S.

2

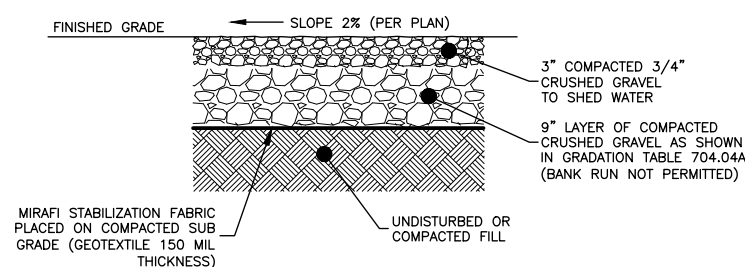

## PARKING AREA DETAIL

SCALE: N.T.S.

4

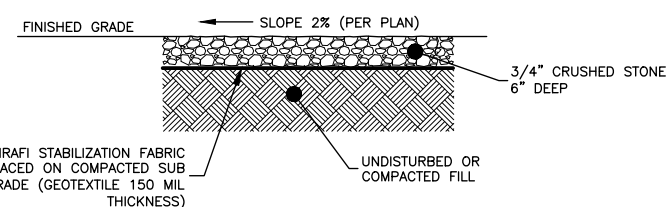

## GRAVEL YARD DETAIL

SCALE: N.T.S.

5

### NOTES:

- ENTRANCE WIDTH SHALL BE A TEN (10) FOOT MINIMUM, BUT NOT LESS THAN THE FULL WIDTH AT POINTS WHERE INGRESS OR EGRESS OCCURS.
- THE ENTRANCE SHALL BE MAINTAINED IN A CONDITION WHICH SHALL PREVENT TRACKING OR FLOWING OF SEDIMENT ONTO PUBLIC RIGHTS-OF-WAY. THIS MAY REQUIRE PERIODIC TOP DRESSING WITH ADDITIONAL STONE AS CONDITIONS DEMAND AND REPAIR OR CLEANOUT OF ANY MEASURES USED TO TRAP SEDIMENT. ALL SEDIMENT SPILLED, DROPPED, WASHED OR TRACKED ONTO PUBLIC RIGHTS-OF-WAY MUST BE REMOVED IMMEDIATELY. BERM SHALL BE PERMITTED. PERIODIC INSPECTION AND MAINTENANCE SHALL BE PROVIDED AS NEEDED.

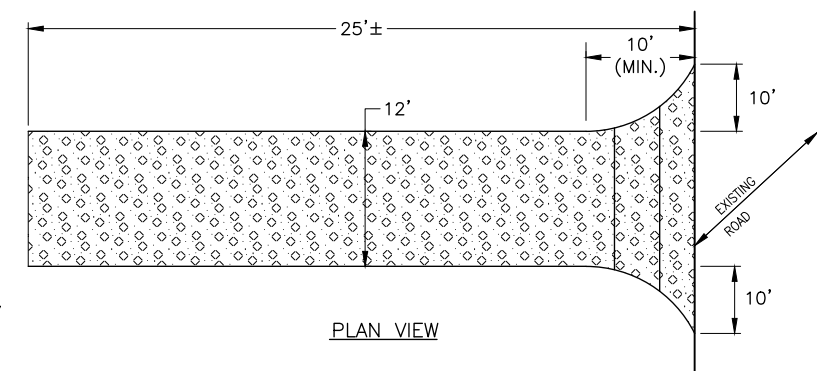

### PLAN VIEW

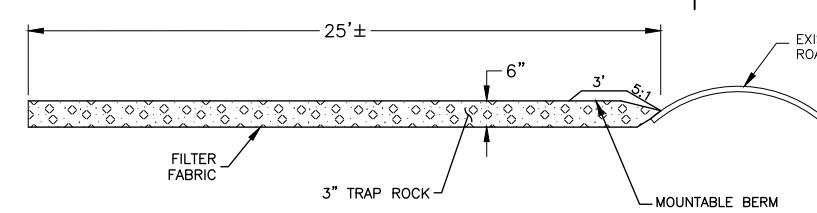

### CROSS-SECTION

## STABILIZED CONSTRUCTION ACCESS

SCALE: N.T.S.

3

DRAWN BY: GMT

REVIEWED BY: DAS

CHECKED BY: BBR

PROJECT NUMBER: 50170469

JOB NUMBER: 50184159

SITE ADDRESS

127 CROW HILL ROAD  
POWNAI, VT 05261

SHEET TITLE

CONSTRUCTION  
DETAILS-1

SHEET NUMBER

C-5

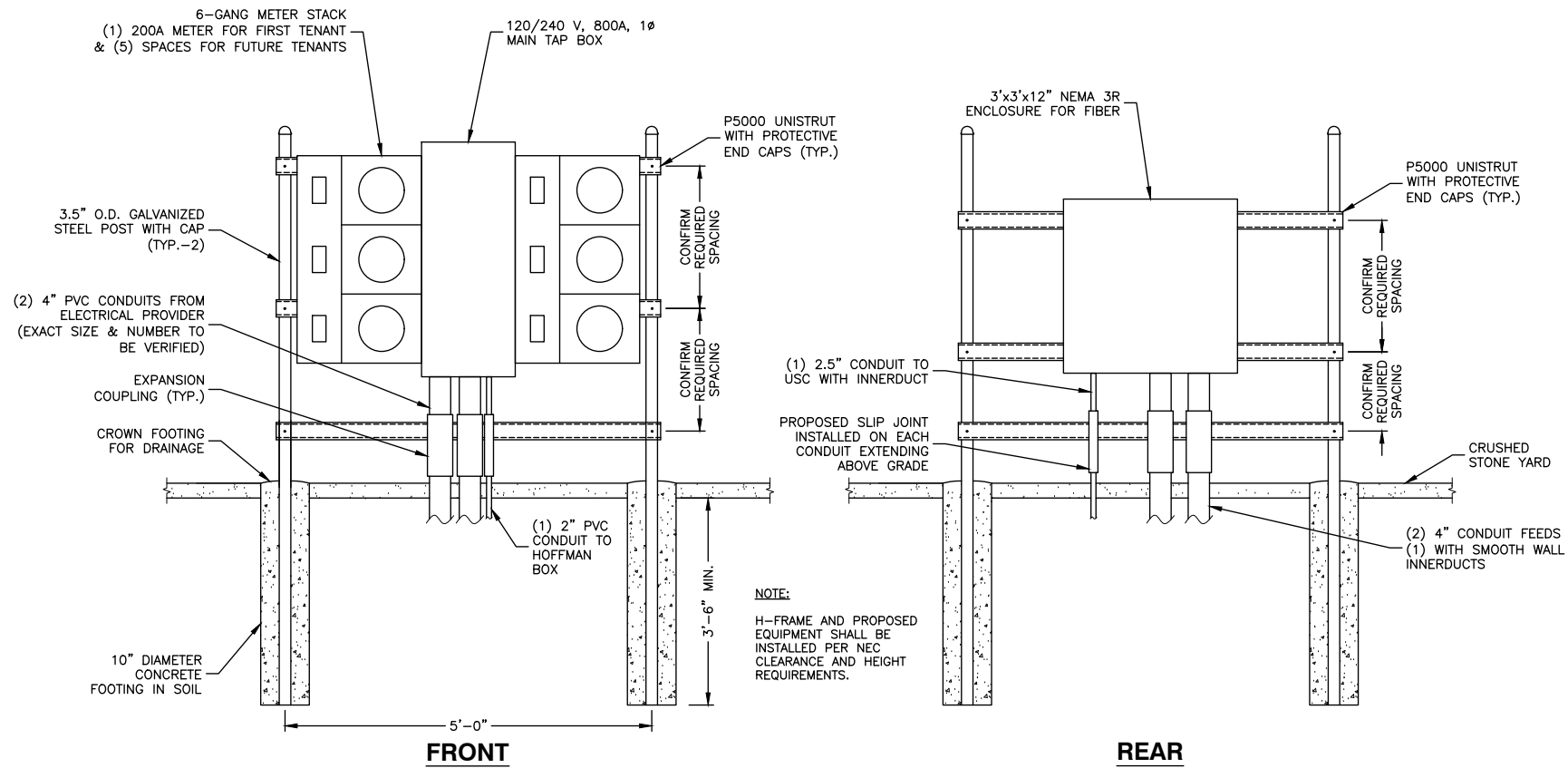

**UTILITY MOUNTING RACK DETAIL**

SCALE: N.T.S.

1

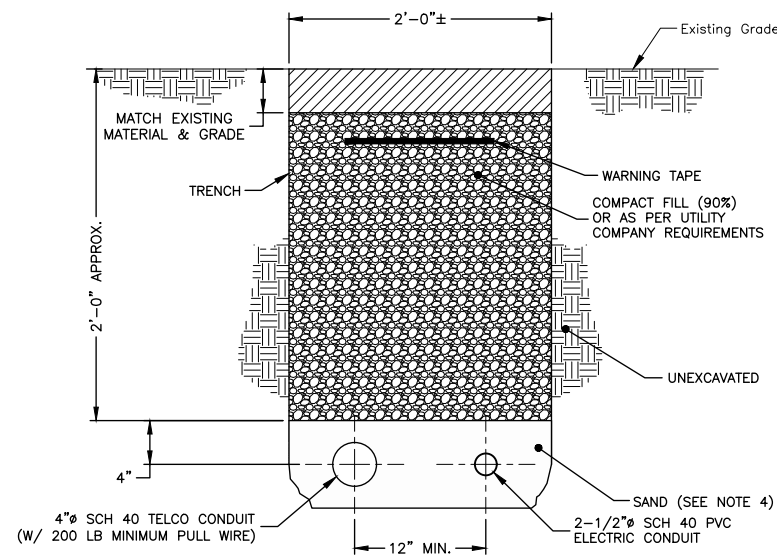

**TRENCH NOTES:**

- IF FREE OF ORGANIC OR OTHER DELETERIOUS MATERIAL, EXCAVATED MATERIAL MAY BE USED FOR BACKFILL. IF NOT, PROVIDE CLEAN, COMPACTIBLE MATERIAL, COMPACT IN 8" LIFTS. REMOVE ANY LARGE ROCKS PRIOR TO BACKFILLING. CONTRACTOR TO VERIFY LOCATION OF EXISTING U/G UTILITIES PRIOR TO DIGGING.
- IF CURRENT AS-BUILT DRAWINGS ARE NOT AVAILABLE CONTRACTOR SHALL HAND DIG U/G TRENCHING.
- CONTRACTOR TO VERIFY SIZE OF CONDUIT WITH WIRING AND TRENCHING INSPECTOR PRIOR TO INSTALLATION.
- CONCRETE ENCASE CONDUITS WHEN TRENCHING UNDER ACCESS ROAD OR PARKING AREA.

**JOINT SERVICE TRENCH BURIED CONDUIT (ELECTRIC/TELEPHONE)**

SCALE: N.T.S.

2

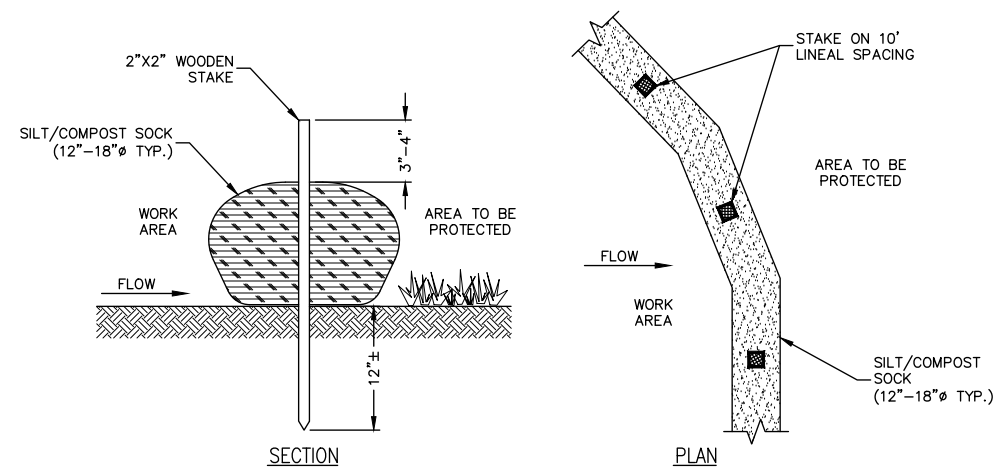

**FILTER SOCK NOTES:**

- NO TRENCHING IS REQUIRED. TIE A KNOT IN ONE END OF THE MESH SOCK, FILL THE SOCK WITH COMPOSTED MATERIAL (USING A PNEUMATIC BLOWER) AND KNOT THE OPPOSITE END ONCE THE DESIRED LENGTH IS ACHIEVED.
- COMPOST FILTER SOCKS SHOULD BE INSPECTED REGULARLY, AS WELL AS AFTER EACH RAINFALL EVENT, TO ENSURE THEY ARE INTACT AND THE AREA BEHIND THE SOCK IS NOT FILLED WITH SEDIMENT. ONCE SEDIMENT REACHES ONE HALF THE HEIGHT OF THE SOCK, REMOVE SEDIMENT BY HAND AND DISPOSE OF PROPERLY.
- REFER TO MANUFACTURER'S SPECIFICATIONS FOR PROPER INSTALLATION AND MAINTENANCE METHODS.

**SEDIMENTATION FILTER SOCK DETAIL**

SCALE: N.T.S.

3

**RIISING TIDE II TOWERS II**

5 MILK STREET  
SUITE 110  
PORTLAND, ME 04101

**POWNAI, VT  
SITE #: RTT2-01**

**CONSTRUCTION DRAWINGS**

C	04/23/25	FOR COMMENT
B	01/08/25	FOR COMMENT
A	11/14/24	FOR COMMENT



Dewberry Engineers Inc.  
99 SUMMER STREET  
SUITE 700  
BOSTON, MA 02110  
PHONE: 617.695.3400  
FAX: 617.695.3310

DRAWN BY:	GMT
REVIEWED BY:	DAS
CHECKED BY:	BBR
PROJECT NUMBER:	50170469
JOB NUMBER:	50184159
SITE ADDRESS	

127 CROW HILL ROAD  
POWNAI, VT 05261

SHEET TITLE

CONSTRUCTION  
DETAILS-II

SHEET NUMBER

C-6

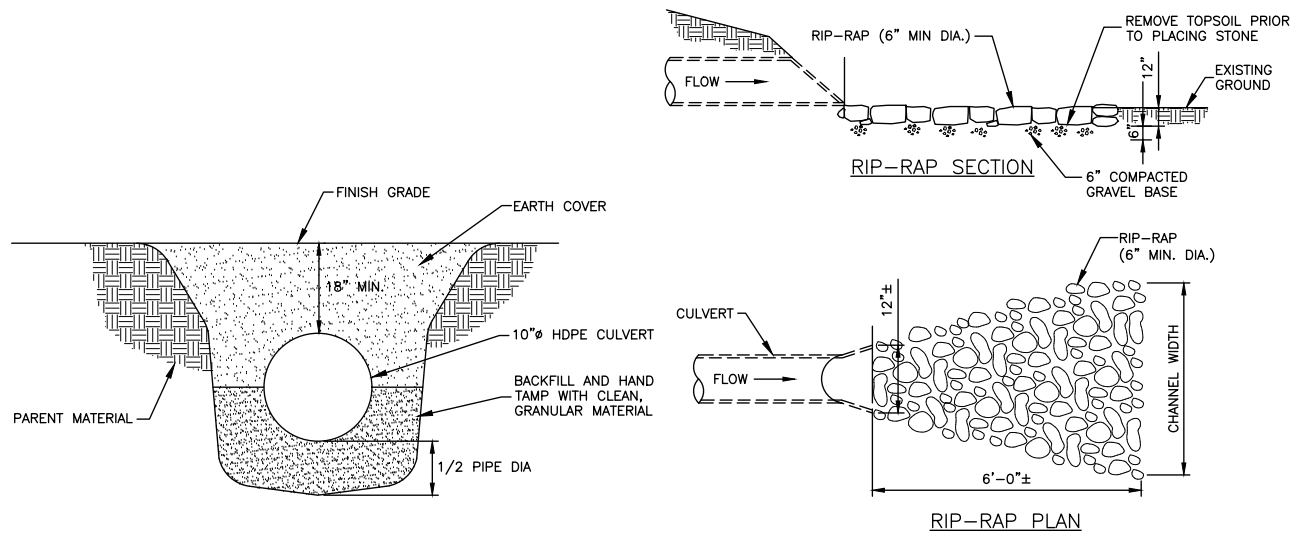

**CULVERT DETAIL** 1  
SCALE: N.T.S.

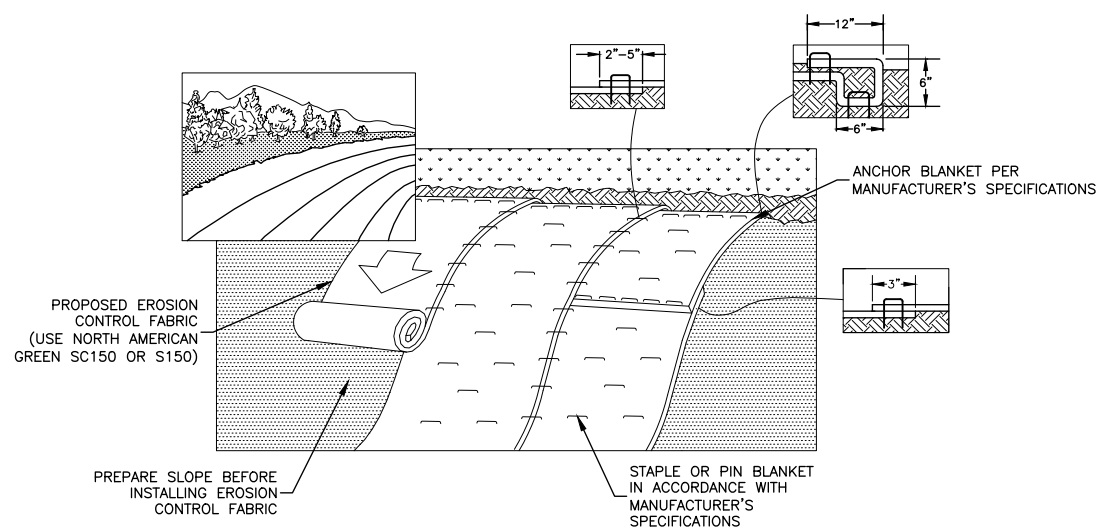

- NOTES:**
1. USE ON SLOPES 3:1 OR GREATER.
  2. REMOVE ALL ROCKS, CLODS, TRASH, VEGETATIVE OR OTHER OBSTRUCTIONS PRIOR TO INSTALLATION. BLANKETS SHALL HAVE GOOD SOIL CONTACT.
  3. PREPARE SEEDBED BY LOOSENING 2-3 INCHES OF TOPSOIL ABOVE FINAL GRADE.
  4. SEED AREA BEFORE BLANKET INSTALLATION FOR EROSION CONTROL AND REVEGETATION.
  5. LAY BLANKETS LOOSELY AND STAKE OR STAPLE TO MAINTAIN DIRECT CONTACT WITH THE SOIL. DO NOT STRETCH.

**EROSION CONTROL BLANKET** 2  
SCALE: N.T.S.

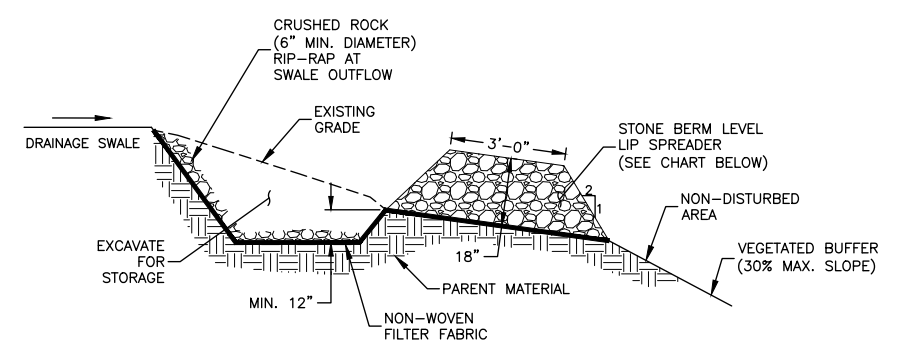

GRADATION OF STONE FOR LEVEL SPREADER BERM	
SIEVE DESIGNATION	PERCENT BY WEIGHT PASSING SQUARE MESH SIEVE
12-INCH	100%
6-INCH	84% - 100%
3-INCH	68% - 83%
1-INCH	42% - 55%
NO. 4	8% - 12%

- NOTES:**
1. LEVEL SPREADER SHALL BE INSTALLED WITH 0% GRADE ON THE SPREADER BASE AND LIP.
  2. LEVEL SPREADER SHALL BE CONSTRUCTED ON UNDISTURBED SOIL WHERE POSSIBLE.

**LEVEL SPREADER DETAIL** 3  
SCALE: N.T.S.

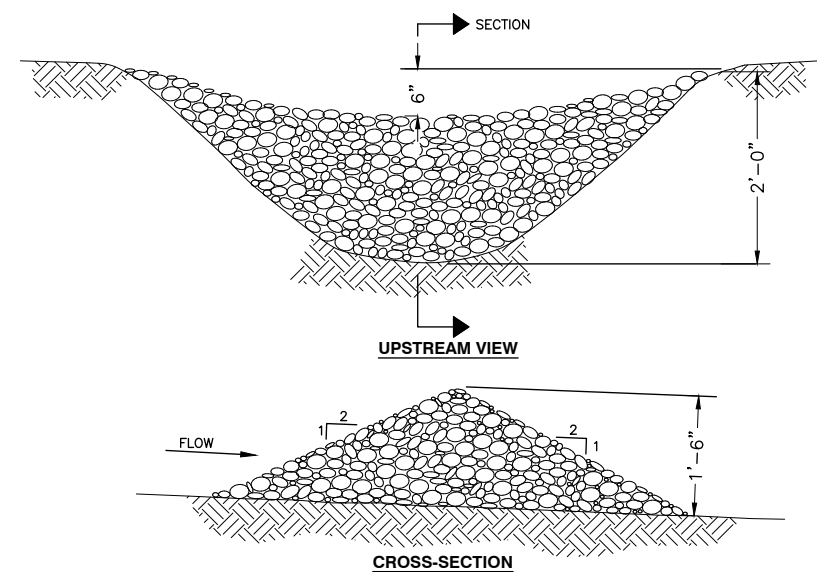

- NOTES:**
1. STONE CHECK DAMS TO BE PLACED AT MAXIMUM 50' INTERVALS ALONG THE RIP-RAP LINED SWALES.
  2. CONSTRUCT DAMS AT APPROXIMATELY 50' INTERVALS.
  3. DURING CONSTRUCTION, SEDIMENT SHALL BE REMOVED WHEN IT REACHES ONE HALF OF THE CHECK DAM HEIGHT.

**STONE CHECK DAM** 4  
SCALE: N.T.S.

# RIISING TIDE II TOWERS II

5 MILK STREET  
SUITE 110  
PORTLAND, ME 04101

**POWNAI, VT  
SITE #: RTT2-01**

**CONSTRUCTION DRAWINGS**

REV	DATE	DESCRIPTION
C	04/23/25	FOR COMMENT
B	01/08/25	FOR COMMENT
A	11/14/24	FOR COMMENT

**Dewberry**<sup>®</sup>  
Dewberry Engineers Inc.  
99 SUMMER STREET  
SUITE 700  
BOSTON, MA 02110  
PHONE: 617.695.3400  
FAX: 617.695.3310

DRAWN BY: GMT  
REVIEWED BY: DAS  
CHECKED BY: BBR  
PROJECT NUMBER: 50170469  
JOB NUMBER: 50184159  
SITE ADDRESS:

127 CROW HILL ROAD  
POWNAI, VT 05261

SHEET TITLE: CONSTRUCTION DETAILS-III  
SHEET NUMBER:

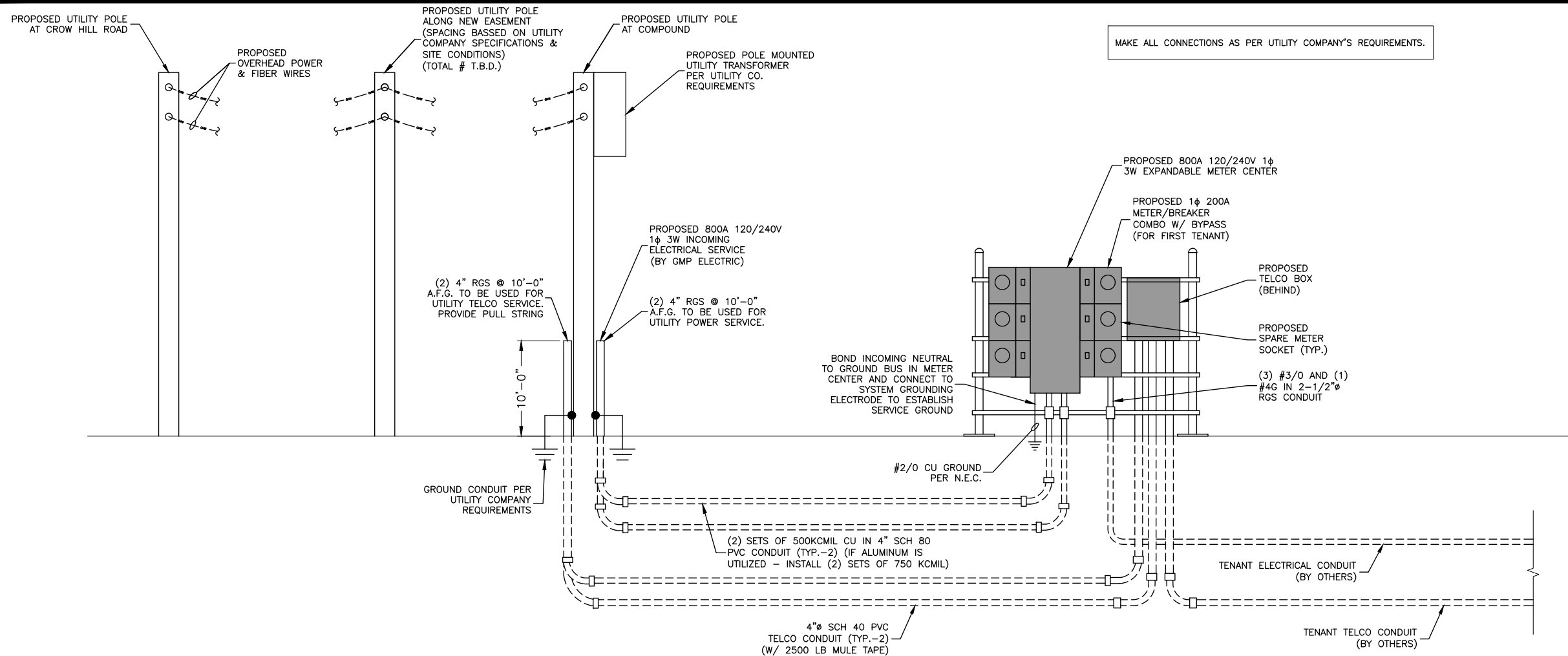

- ALL ELECTRICAL WORK SHALL BE DONE IN ACCORDANCE WITH ALL GOVERNING STATE, COUNTY & LOCAL CODES, O.S.H.A., NEC, NFPA #70, RISING TIDE TOWERS SPECIFICATIONS, & THE SPECIFICATIONS DETAILED IN THESE PLANS.
- SUBMITTAL OF BID INDICATES CONTRACTOR IS COGNIZANT OF ALL JOB SITE CONDITIONS & WORK TO BE PERFORMED UNDER THIS CONTRACT.
- CONTRACTOR SHALL PERFORM ALL VERIFICATION, OBSERVATION, TESTS, & EXAMINATION WORK PRIOR TO THE ORDERING OF THE ELECTRICAL EQUIPMENT & THE ACTUAL CONSTRUCTION. CONTRACTOR SHALL ISSUE A WRITTEN NOTICE OF ALL FINDINGS TO THE PROJECT MANAGER LISTING ALL MALFUNCTIONS, FAULTY EQUIPMENT, & DISCREPANCIES.
- THESE PLANS ARE DIAGRAMMATIC ONLY, FOLLOW AS CLOSELY AS POSSIBLE. CONTRACTOR SHALL ENSURE THAT ACCESS TO EQUIPMENT IS MAINTAINED IN ACCORDANCE WITH MANUFACTURER SPECIFICATIONS & ALL APPLICABLE CODES.
- EACH CONDUCTOR OF EVERY SYSTEM SHALL BE PERMANENTLY TAGGED IN EACH PANELBOARD, PULLBOX, J-BOX, SWITCH BOX, ETC., IN COMPLIANCE WITH OCCUPATIONAL SAFETY & HEALTH ADMINISTRATION (OSHA).
- CONTRACTOR SHALL PROVIDE ALL LABOR, MATERIALS, INSURANCE, EQUIPMENT, INSTALLATION, CONSTRUCTION TOOLS, TRANSPORTATION, ETC., FOR A COMPLETE & PROPERLY OPERATIVE SYSTEM, ENERGIZED THROUGHOUT & AS INDICATED ON DRAWINGS, AS SPECIFIED HEREIN AND/OR AS OTHERWISE REQUIRED.
- ALL MATERIALS & EQUIPMENT SHALL BE NEW & IN PERFECT CONDITION WHEN INSTALLED & SHALL BE OF THE BEST GRADE & OF THE SAME MANUFACTURER THROUGHOUT FOR EACH CLASS OR GROUP OF EQUIPMENT. MATERIALS SHALL BE LISTED & APPROVED BY UNDERWRITER'S LABORATORY & SHALL BEAR THE INSPECTION LABEL "J" WHERE SUBJECT TO SUCH APPROVAL. MATERIALS SHALL MEET WITH APPROVAL OF ALL GOVERNING BODIES HAVING JURISDICTION. MATERIALS SHALL BE MANUFACTURED IN ACCORDANCE WITH APPLICABLE STANDARDS ESTABLISHED BY ANSI, NEMA, IEEE, & NFPA.
- ALL CONDUIT INSTALLED MAY BE SURFACE MOUNTED UNLESS OTHERWISE NOTED.
- COMPLETE JOB SHALL BE GUARANTEED FOR A PERIOD OF ONE (1) YEAR AFTER THE DATE OF JOB ACCEPTANCE BY OWNER. ANY WORK, MATERIAL OR EQUIPMENT FOUND TO BE FAULTY DURING THAT PERIOD SHALL BE CORRECTED AT ONCE, UPON WRITTEN NOTIFICATION, AT THE EXPENSE OF THE CONTRACTOR.
- ALL "CONDUIT ONLY" (C.O.) INSTALLATIONS SHALL HAVE A 3/8" PULL WIRE OR ROPE.
- CONTRACTOR SHALL PROVIDE RISING TIDE TOWERS MANAGER WITH ONE SET OF COMPLETE ELECTRICAL "AS INSTALLED" DRAWINGS AT THE COMPLETION OF THE JOB, SHOWING ACTUAL DIMENSIONS, ROUTINGS, & CIRCUITS.
- ALL BROCHURES, OPERATING MANUALS, CATALOGS, SHOP DRAWINGS, ETC. SHALL BE TURNED OVER TO OWNER AT JOB COMPLETION.
- POWER WIRE & CABLE CONDUCTORS SHALL BE COPPER #12 AWG MINIMUM UNLESS SPECIFICALLY NOTED OTHERWISE ON DRAWINGS. CONDUCTORS #10 AWG & SMALLER SHALL BE SOLID.
- ALL CONDUCTORS LARGER THAN #10 AWG SHALL BE STRANDED COPPER WITHIN 600V INSULATION, UNLESS NOTED OTHERWISE.
- ALL MATING SURFACES OF GROUND CONNECTIONS SHALL BE CLEANED SMOOTH & COATED WITH ANTI-OXIDANT PRIOR TO ATTACHMENT.
- ALL GROUND CONNECTIONS BELOW GRADE MUST BE EXOTHERMICALLY WELDED (CAD WELD OR APPROVED EQUAL)
- ALL EXTERIOR GROUNDING CONDUCTORS SHALL BE #2 AWG SOLID TINNED BARE COPPER WIRE UNLESS NOTED OTHERWISE.
- ALL CIRCUIT BREAKERS, FUSES & ELECTRICAL EQUIPMENT SHALL HAVE AN INTERRUPTING RATING NOT LESS THAN THE MAXIMUM SHORT CIRCUIT CURRENT TO WHICH THEY MAY BE SUBJECTED, & A MINIMUM OF 10,000 A.I.C. COORDINATE SHORT CIRCUIT REQUIREMENTS WITH LOCAL UTILITY COMPANY.

- CONTRACTOR SHALL PATCH, REPAIR, & PAINT ANY AREA THAT HAS BEEN DAMAGED IN THE COURSE OF THE ELECTRICAL WORK.
- IN DRILLING HOLES INTO CONCRETE WHETHER FOR FASTENING OR ANCHORING PURPOSES, OR PENETRATIONS THROUGH THE FLOOR FOR CONDUIT RUNS, M PIPE RUNS, ETC., IT MUST BE CLEARLY UNDERSTOOD THAT TENDONS AND/OR REINFORCING STEEL WILL NOT BE DRILLED INTO, CUT OR DAMAGED UNDER ANY CIRCUMSTANCES.
- LOCATION OF TENDONS AND/OR REINFORCING STEEL ARE NOT DEFINITELY KNOWN &, THEREFORE, MUST BE SEARCHED FOR BY APPROPRIATE METHODS & EQUIPMENT VIA X-RAY OR OTHER DEVICES THAT CAN ACCURATELY LOCATE THE REINFORCING AND/OR STEEL TENDONS.
- PENETRATIONS IN FIRE RATED WALLS SHALL BE SEALED IN ACCORDANCE WITH ALL APPLICABLE CODES.
- ALL MATERIALS SHALL BE U.L. LISTED.
- CONDUIT:
  - RIGID CONDUIT SHALL BE U.L. LABEL GALVANIZED ZINC COATED WITH ZINC INTERIOR & SHALL BE USED WHEN INSTALLED IN OR UNDER CONCRETE SLABS, IN CONTACT WITH THE EARTH, UNDER PUBLIC ROADWAYS, IN MASONRY WALLS OR EXPOSED ON BUILDING EXTERIOR. RIGID CONDUIT IN CONTACT WITH EARTH SHALL BE 1/2 LAPPED RAPPED WITH HUNTS WRAP PROCESS NO. 3.
  - ELECTRICAL METALLIC TUBING SHALL HAVE U.L. LABEL. FITTINGS SHALL BE GLAND RING COMPRESSION TYPE. EMT SHALL BE USED ONLY FOR INTERIOR RUNS.
  - FLEXIBLE METALLIC CONDUIT SHALL HAVE U.L. LISTED LABEL & MAY BE USED WHERE PERMITTED BY CODE. FITTINGS SHALL BE "JAKE" OR "SQUEEZE" TYPE, SEAL TIGHT FLEXIBLE CONDUIT. ALL CONDUIT SHALL HAVE FULL SIZE GROUND WIRE.
  - CONDUIT RUNS MAY BE SURFACE MOUNTED IN CEILINGS OR WALLS UNLESS INDICATED OTHERWISE. CONDUIT SHALL RUN PARALLEL OR AT RIGHT ANGLES TO CEILING, FLOOR OR BEAMS. VERIFY EXACT ROUTING OF ALL EXPOSED CONDUIT WITH ENGINEER PRIOR TO INSTALLING.
- ALL ELECTRICAL EQUIPMENT SHALL BE LABELED WITH PERMANENT ENGRAVED PLASTIC LABELS.
- CONTRACTOR SHALL COORDINATE THE ELECTRICAL SERVICE WITH RISING TIDE TOWERS & LOCAL UTILITY.
- THE ENTIRE ELECTRICAL INSTALLATION SHALL BE GROUNDED AS REQUIRED BY NEC & ALL APPLICABLE CODES.
- GROUNDING SYSTEM RESISTANCE SHALL NOT EXCEED 5 OHMS. IF THE RESISTANCE VALUE IS EXCEEDED, NOTIFY THE OWNER FOR FURTHER INSTRUCTION ON METHODS FOR REDUCING THE RESISTANCE VALUE. CONTRACTOR SHALL SUBMIT TO THE PROJECT MANAGER ALL TEST REPORTS & ONE COMPLETE SET OF PRINTS SHOWING "INSTALLED WORK".
- UPON COMPLETION OF WORK, CONDUCT CONTINUITY, & FALL OF POTENTIAL GROUNDING TESTS FOR APPROVAL. SUBMIT TEST REPORTS TO PROJECT MANAGER. CLEAN PREMISES OF ALL DEBRIS RESULTING FROM WORK & LEAVE WORK IN A COMPLETE & UNDAMAGED CONDITION.
- ALL EXPOSED GROUND WIRES ROUTED ALONG THE SIDE OF EQUIPMENT SHELTERS OR ROUTED OVER CONCRETE FOUNDATIONS OR OTHER EXISTING STRUCTURES SHALL BE INSTALLED IN PROPERLY ANCHORED 3/4" (MIN.) PVC CONDUIT.
- CONTRACTOR SHALL NOT DISTURB EXISTING GROUNDING SYSTEM. ANY DAMAGE SHALL BE REPAIRED IMMEDIATELY AT NO ADDITIONAL COST.
- ALL ELEMENTS OF ICE BRIDGE & RISING TIDE TOWERS UTILITY BACKBOARD MUST BE BONDED & JUMPED TO GROUNDED COMPONENTS OF THESE SYSTEMS.
- ALL INTERIOR CABLES & WIRING SHALL BE NEATLY ROUTED IN OVERHEAD LADDER RACK & FASTENED TO LADDER RACK.
- ALL GROUNDING CONDUCTORS SHALL BE ROUTED DOWNWARDS FROM POINT OF ORIGIN TO TERMINATION POINT (GROUND BAR, GROUND RING, ETC.).

- GROUNDING CONDUCTORS SHALL NOT REVERSE DIRECTION (EXCEPT HALO & BURIED GROUND RINGS). OTHER EXCEPTIONS NEED TO BE APPROVED BY RISING TIDE TOWERS CONSTRUCTION MANAGER PRIOR TO INSTALLATION.
- GROUNDING CONDUCTORS SHALL HAVE A MINIMUM BENDING RADIUS OF 8".
- ALL CONNECTIONS TO GROUND PLATES SHALL BE CAD WELDED TO THE CENTER OF THE PLATE. ALL DETAILS SHOWING CONNECTIONS TO GROUND RODS ARE ALSO VALID FOR SIMILAR CONNECTIONS TO GROUND PLATES.
- FOLLOWING COMPLETION OF WORK, PROVIDE OWNER WITH AS-BUILT DRAWINGS SHOWING TELEPHONE & ELECTRIC LOCATIONS.
- WORK SHALL CONFORM TO THE NATIONAL ELECTRICAL CODE.
- COORDINATE WITH UTILITY & LOCAL ELECTRICAL INSPECTOR FOR FINAL POWER CONNECTION.
- UTILITY WILL SUPPLY METER. COORDINATE WITH UTILITY FOR METER TYPE & INTERCONNECTION.
- ALL EXISTING UNDERGROUND LINES ON SITE TO BE LOCATED PRIOR TO CONSTRUCTION. CALL DIGSAFE 1-888-DIG-SAFE OR 811 PRIOR TO CONSTRUCTION.
- SEAL ALL SERVICE ENTRANCES INTO SHELTER FOLLOWING INSTALLATION.
- COORDINATE WITH LOCAL TELEPHONE COMPANY FOR ALL ROUTING & DESIGN.
- CONTRACTOR TO VERIFY CONTROL WIRING SIZE WITH GENERATOR MANUFACTURER PRIOR TO CONSTRUCTION.

#### UTILITY COMPANY CONTACTS

POWER COMPANY: GREEN MOUNTAIN POWER  
1-888-835-4672

TELEPHONE COMPANY: FIRSTLIGHT FIBER  
1-833-484-0404

# RISING TIDE II TOWERS II

5 MILK STREET  
SUITE 110  
PORTLAND, ME 04101

**POWNAI, VT  
SITE #: RTT2-01**

#### CONSTRUCTION DRAWINGS

REV	DATE	DESCRIPTION
C	04/23/25	FOR COMMENT
B	01/08/25	FOR COMMENT
A	11/14/24	FOR COMMENT



Dewberry Engineers Inc.  
99 SUMMER STREET  
SUITE 700  
BOSTON, MA 02110  
PHONE: 617.695.3400  
FAX: 617.695.3310

DRAWN BY: GMT

REVIEWED BY: DAS

CHECKED BY: BBR

PROJECT NUMBER: 50170469

JOB NUMBER: 50184159

SITE ADDRESS

127 CROW HILL ROAD  
POWNAI, VT 05261

SHEET TITLE

ELECTRICAL & TELCO  
RISER DIAGRAM

SHEET NUMBER

## GROUNDING GENERAL NOTES

- ALL DOWN CONDUCTORS & THE GROUNDING RING CONDUCTOR SHALL BE #2 AWG, SOLID, BARE, TINNED COPPER, UNLESS OTHERWISE NOTED. ALL CONNECTIONS TO GROUNDING RING SHALL BE EXOTHERMICALLY WELDED. CONDUCTOR SHALL BE AT A MINIMUM DEPTH BELOW GRADE OF 30" OR TO LEDGE. MINIMUM BEND RADIUS SHALL BE 8 INCHES. CONDUCTOR SHALL BE AT LEAST 24 INCHES FROM ANY FOUNDATION, UNLESS OTHERWISE NOTED.
- GROUND RODS SHALL BE 5/8" DIAMETER COPPER CLAD, HARGER, T&B, ERICO, OR EQUIVALENT. TOP OF ROD SHALL BE A MINIMUM OF 30" BELOW GRADE. IF LEDGE IS ENCOUNTERED, INSTALL GROUND ROD AT AN ANGLE. ELECTRICAL METER GROUND ROD EXCEPTED.
- WHERE MECHANICAL CONNECTIONS ARE SPECIFIED, BOLTED, COMPRESSION-TYPE, CLAMPS OR SPLIT-BOLT TYPE CONNECTORS SHALL BE USED.
- GRIND OFF GALVANIZING IN AFFECTED AREA. EXOTHERMICALLY WELD #2 CONDUCTOR AT 6" ABOVE GRADE OR FOUNDATION, WHICHEVER IS HIGHER. COLD-GALV AFTER. EXOTHERMICALLY WELD OTHER END TO GROUND RING.
- INSTALL GROUNDING KITS AT ANTENNA & TOWER EXIT POINTS. GROUND HYBRID/COAX LINES. EXOTHERMICALLY WELD #2 DOWN CONDUCTOR TO PLATES, RUN DOWN TOWER, & TIE INTO GROUNDING SYSTEM.
- ALL GROUNDING WORK SHALL COMPLY WITH RTT2 STANDARDS. FOLLOWING COMPLETION OF WORK, GROUND SYSTEM MUST BE TESTED & SHALL HAVE A RESISTANCE OF 5 OHMS OR LESS SUBMIT AN INDEPENDENT "FALL POTENTIAL" TESTING REPORT.
- CONTRACTOR SHALL HAND-DIG IN AREAS AROUND EXISTING UTILITIES.
- NOTIFY CONSTRUCTION ENGINEER IF THERE ARE ANY DIFFICULTIES INSTALLING GROUNDING SYSTEM DUE TO SITE SOIL CONDITIONS.
- GROUNDING RING IS SHOWN AS SCHEMATIC ONLY. IT IS DESIGNED WITHOUT BENEFIT OF RESISTIVITY TESTING & DOES NOT NECESSARILY REPRESENT A GROUNDING SYSTEM TO MEET ANY SPECIFIC GROUND RESISTANCE.
- PRIOR TO POURING CONCRETE, ALL REBAR LOCATED NEAR THE BOTTOM OF THE FOUNDATION SHALL BE BONDED TOGETHER TO FORM A SINGLE GROUNDING ELECTRODE, BY STEEL TIES OF OTHER EFFECTIVE MEANS APPROVED BY N.E.C. & STRUCTURAL ENGINEER, & BONDED TO THE GROUND RING AS DETAILED IN THESE PLANS (INSPECTION MAY BE REQUIRED PRIOR TO POURING CONCRETE & MUST BE COORDINATED BY CONTRACTOR).
- IN ACCORDANCE WITH N.E.C. REQUIREMENTS, ALL GROUNDING ELECTRODES PRESENT ON SITE SHALL BE BONDED TOGETHER (REFERENCE N.E.C. ARTICLE 250.50).

PROPOSED CHAIN LINK FENCE  
(GATE ASSEMBLY TO BE BONDED TO MAIN  
FENCE ASSEMBLY WITH BRAIDED COPPER  
GROUND STRAPS, SEE DETAIL 1 SHEET C-5)  
(4 CORNER POSTS TO BE BONDED TO  
PROPOSED TOWER GROUND RING)

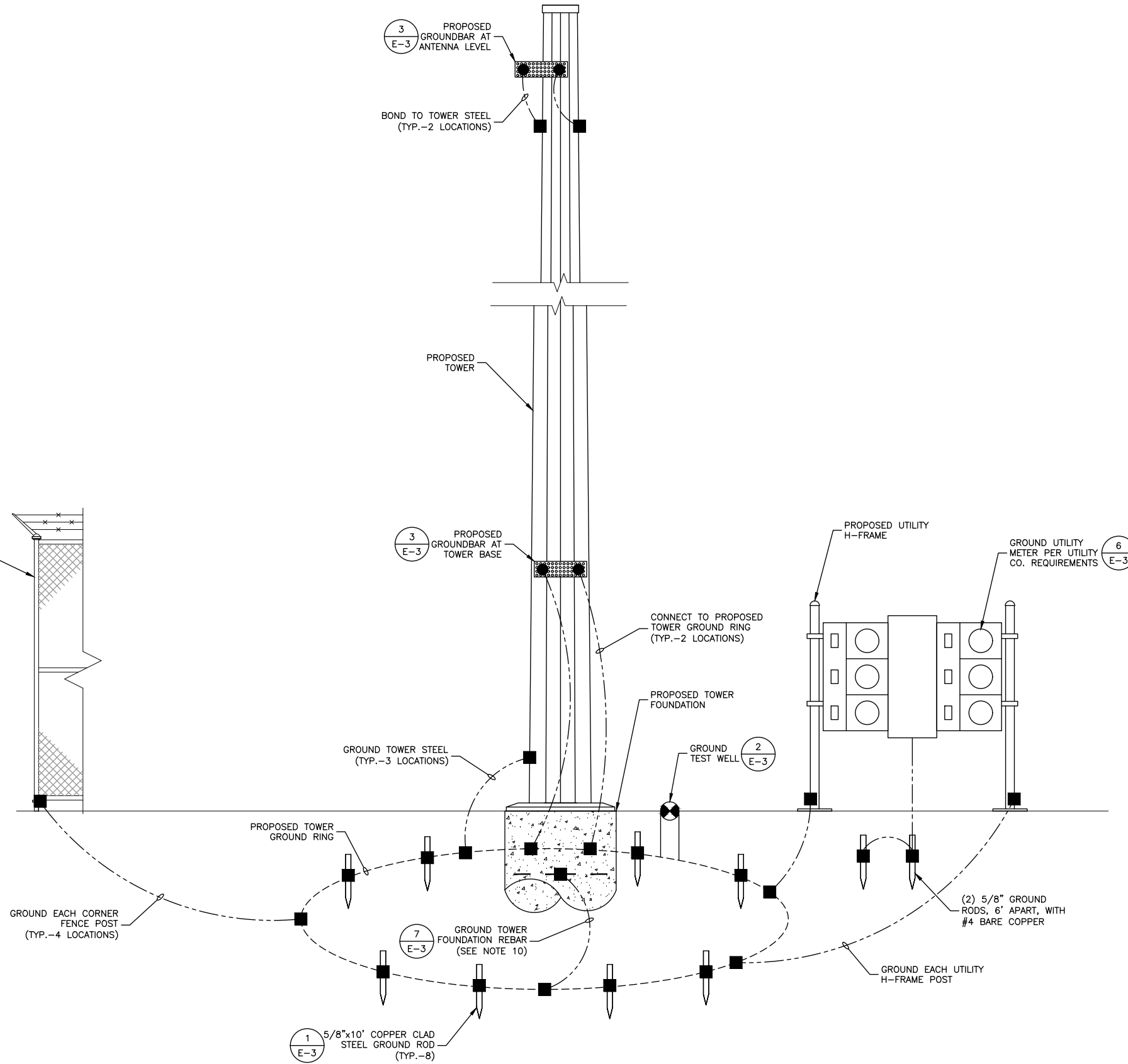

## SCHEMATIC GROUNDING PLAN

SCALE: N.T.S.

1

# RISEING TIDE II TOWERS II

5 MILK STREET  
SUITE 110  
PORTLAND, ME 04101

**POWNAI, VT  
SITE #: RTT2-01**

### CONSTRUCTION DRAWINGS

NO.	DATE	REVISION
C	04/23/25	FOR COMMENT
B	01/08/25	FOR COMMENT
A	11/14/24	FOR COMMENT



**Dewberry Engineers Inc.**  
99 SUMMER STREET  
SUITE 700  
BOSTON, MA 02110  
PHONE: 617.695.3400  
FAX: 617.695.3310

DRAWN BY: GMT

REVIEWED BY: DAS

CHECKED BY: BBR

PROJECT NUMBER: 50170469

JOB NUMBER: 50184159

SITE ADDRESS

127 CROW HILL ROAD  
POWNAI, VT 05261

SHEET TITLE

SCHEMATIC  
GROUNDING PLAN

SHEET NUMBER

E-2

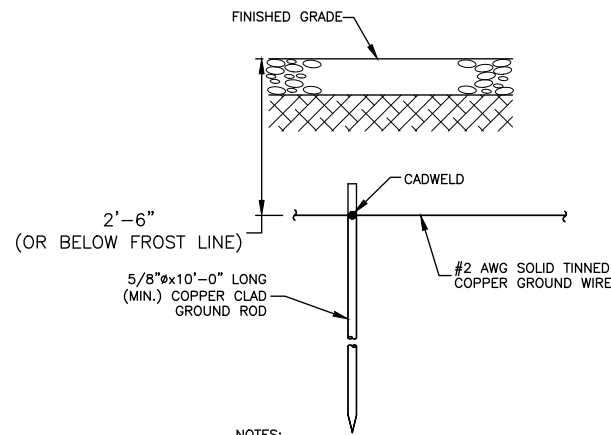

**NOTES:**

1. CADWELD TO GROUND RING AFTER GROUND ROD HAS BEEN DRIVEN INTO PLACE.

**GROUND ROD**

SCALE: N.T.S.

1

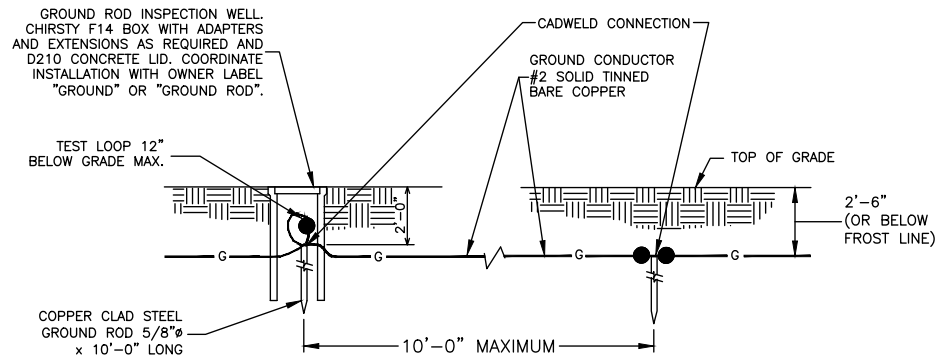

**GROUND TEST WELL**

SCALE: N.T.S.

2

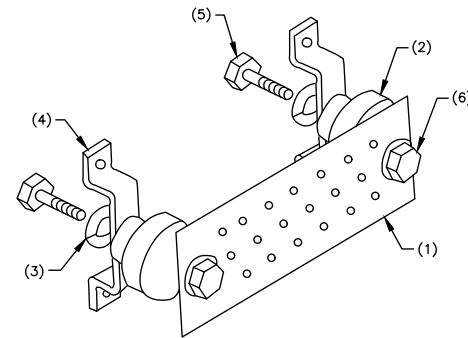

**LEGEND:**

1. INSULATED COPPER GROUND BAR KIT WITH WALL BRACKETS, 1/4"x4"x24", NEWTON INSTRUMENT COMPANY CAT. #2141910100
- (2) INSULATORS (INCLUDED)
- (2) 1/2" LOCKWASHERS (INCLUDED)
- (2) WALL MOUNTING BRACKET (INCLUDED)
- (2) 1/2-13 X 1" H.H.C.S. (INCLUDED)
- (2) 1/2-13 X 7/8" H.H.C.S. (INCLUDED)

**NOTE:**

1. PROVIDE MOUNTING HARDWARE & FIELD LOCATE BASED ON SITE CONDITIONS.

**TOWER GROUND BAR PLATE (TYP.)**

SCALE: N.T.S.

3

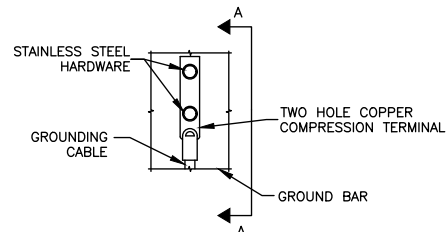

**ELEVATION**

**NOTES:**

1. DOUBLING UP OR STACKING OF CONNECTIONS IS NOT PERMITTED
2. OXIDE INHIBITING COMPOUND TO BE USED AT ALL LOCATIONS.

**TYPICAL GROUND BAR MECHANICAL CONNECTION DETAIL**

SCALE: N.T.S.

4

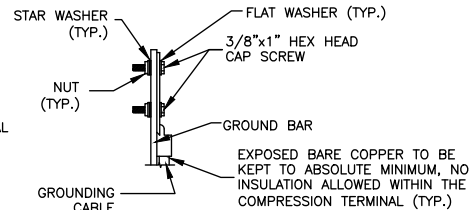

**SECTION 'A-A'**

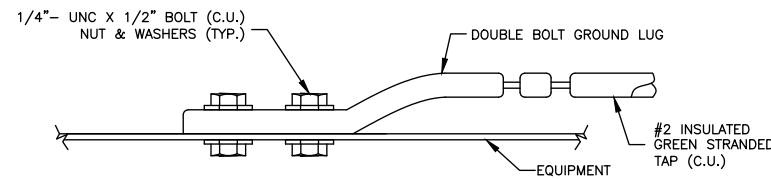

**GROUND EQUIPMENT**

SCALE: N.T.S.

5

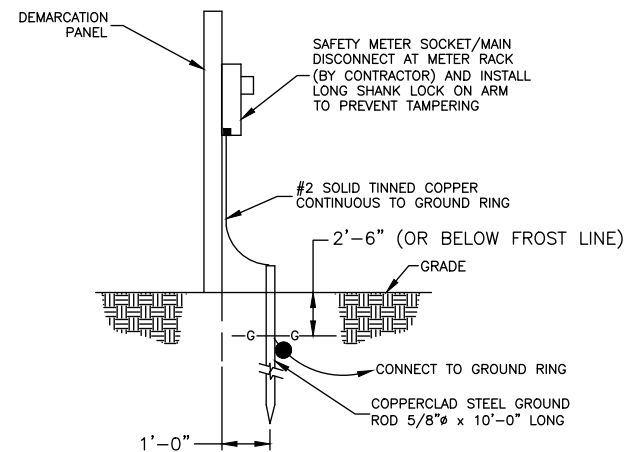

**METER SOCKET GROUNDING**

SCALE: N.T.S.

6

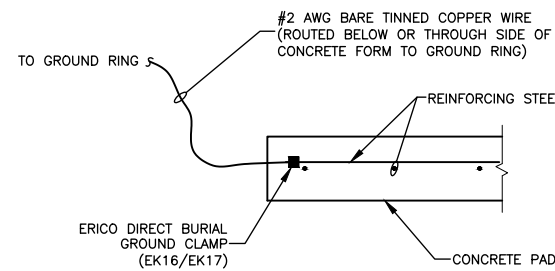

**REBAR GROUNDING DETAIL**

SCALE: N.T.S.

7

**RISEING TIDE II TOWERS II**

5 MILK STREET  
SUITE 110  
PORTLAND, ME 04101

**POWNAI, VT  
SITE #: RTT2-01**

**CONSTRUCTION DRAWINGS**

C	04/23/25	FOR COMMENT
B	01/08/25	FOR COMMENT
A	11/14/24	FOR COMMENT



**Dewberry Engineers Inc.**  
99 SUMMER STREET  
SUITE 700  
BOSTON, MA 02110  
PHONE: 617.695.3400  
FAX: 617.695.3310

DRAWN BY: GMT

REVIEWED BY: DAS

CHECKED BY: BBR

PROJECT NUMBER: 50170469

JOB NUMBER: 50184159

SITE ADDRESS

127 CROW HILL ROAD  
POWNAI, VT 05261

SHEET TITLE

GROUNDING DETAILS

SHEET NUMBER